

BELGRADE

STEEL TANK



PRODUCT CATALOG



Mission Statement

To design and manufacture high quality, competitively priced equipment for the concrete industry, provide a safe and respectful work environment for our valued employees, and continue to support our customers and community.

About Us

Established in 1963 by family patriarch, Mitchell Thompson, the company has enjoyed steady growth and renovation. Specializing in silos for the concrete industry, Belgrade Steel Tank manufactures and deals in a broad line of product, such as aggregate bins, scale hoppers, dust control equipment, belt conveyors, screw conveyors, charging hoppers, and a number of specialty units for industry related needs.

Contact Information

Phone: 320-254-8246

Email: sales@belgradesteeltank.com

Website: www.belgradesteeltank.com

Table of Contents

Basic Silos	4
Split Silos	13
Structural Stands	18
Portable Silos.....	20
Portable Split Silos.....	36
Low Profile Portable Silos.....	42
Batching Silos.....	46
Cement Scale Hoppers.....	47
Aggregate Scale Hoppers and Belt Conveyors.....	48
Decumulative Aggregate Scale Hoppers	50
Aggregate Bins	52
Vertical Liquid Tanks.....	56
Batching and Equipment Controls.....	58
Dust Collectors	66
Auger Worksheet.....	70
Parts and Accessories.....	74

Belgrade Basic Cement Silo

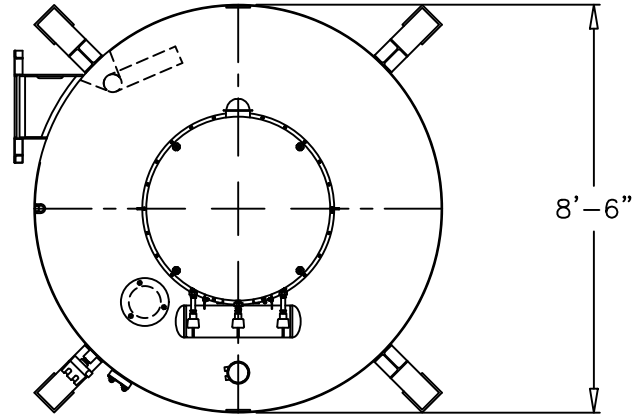

Table of Contents

185 Barrel Basic Silo.....	5
270 Barrel Basic Silo.....	6
350 Barrel Basic Silo.....	7
550 Barrel Basic Silo.....	8
700 Barrel Basic Silo.....	9
900 Barrel Basic Silo.....	10
1050 Barrel Basic Silo.....	11
1200 Barrel Basic Silo.....	12
500 Barrel Split Silo.....	13
700 Barrel Split Silo.....	14
850 Barrel Split Silo.....	15
1000 Barrel Split Silo.....	16
1200 Barrel Split Silo.....	17

185 Barrel Basic Cement Silo

**BELGRADE
STEEL TANK**



185 Barrel Basic Cement Silo

- 8'-6" Diameter x 24'-5" Overall Height
- 330 Sq. Ft. Pulse Jet Dust Collector
- Pressure Relief Valve
- 3'-8" Clearance Under Discharge
- Outside Ladder with OSHA Compliant Fall Arrest Cable System
- 4" Fill Pipe with Aluminum Adapter
- 20" Non-Pressurized Inspection Manhole
- Solimar Disc Package
- 10" Emergency Jam Gate
- Sandblast, Prime, and Paint
- Standard Colors:
 - RAL 7038 Gray, RAL 9010 White, RAL 1001 Tan, RAL 1032 Yellow

Options

- 150 Sq. Ft. Dust Collector with Air Vibrator
- Bin Level Indicators
- Manual Air Valve Controls
- 10" or 12" Butterfly Valve
- 5" Fill Pipe
- 12" Emergency Jam Gate

Specifications

- Empty Weight 6,000#
- 740 Cu. Ft. Capacity
- 34 Ton Capacity (Cement)
- Part Number: BST185-86

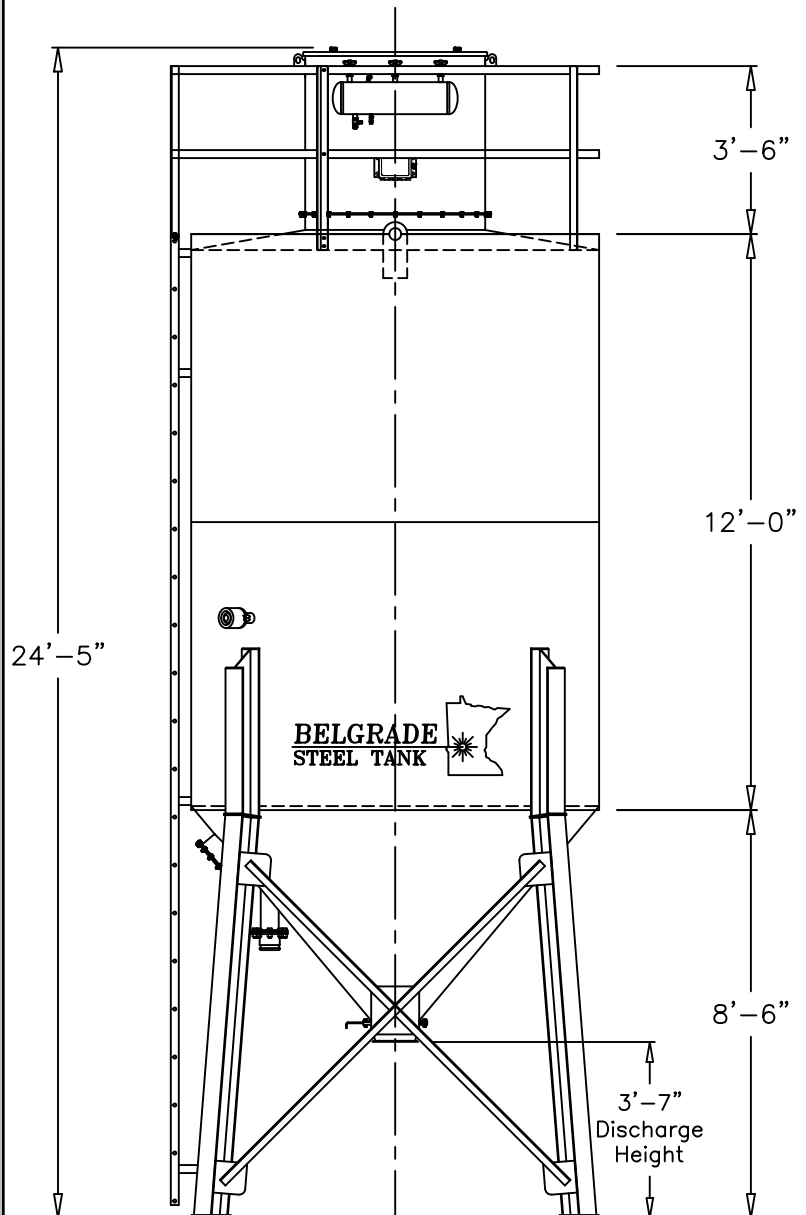

270 Barrel Basic Cement Silo

**BELGRADE
STEEL TANK**



270 Barrel Basic Cement Silo

- 8'-6" Diameter x 30'-5" Overall Height
- 330 Sq. Ft. Pulse Jet Dust Collector
- Pressure Relief Valve
- 3'-8" Clearance Under Discharge
- Outside Ladder with OSHA Compliant Fall Arrest Cable System
- 4" Fill Pipe with Aluminum Adapter
- 20" Non-Pressurized Inspection Manhole
- Solimar Disc Package
- 10" Emergency Jam Gate
- Sandblast, Prime, and Paint
- Standard Colors:
 - RAL 7038 Gray, RAL 9010 White, RAL 1001 Tan, RAL 1032 Yellow

Options

- 150 Sq. Ft. Bag Area Dust Collector with Air Vibrator
- Bin Level Indicators
- Manual Air Valve Controls
- 10" or 12" Butterfly Valve
- 5" Fill Pipe
- 12" Emergency Jam Gate

Specifications

- Empty Weight 7,000#
- 1,080 Cu. Ft. Capacity
- 50 Ton Capacity (Cement)
- Part Number: BST270-86

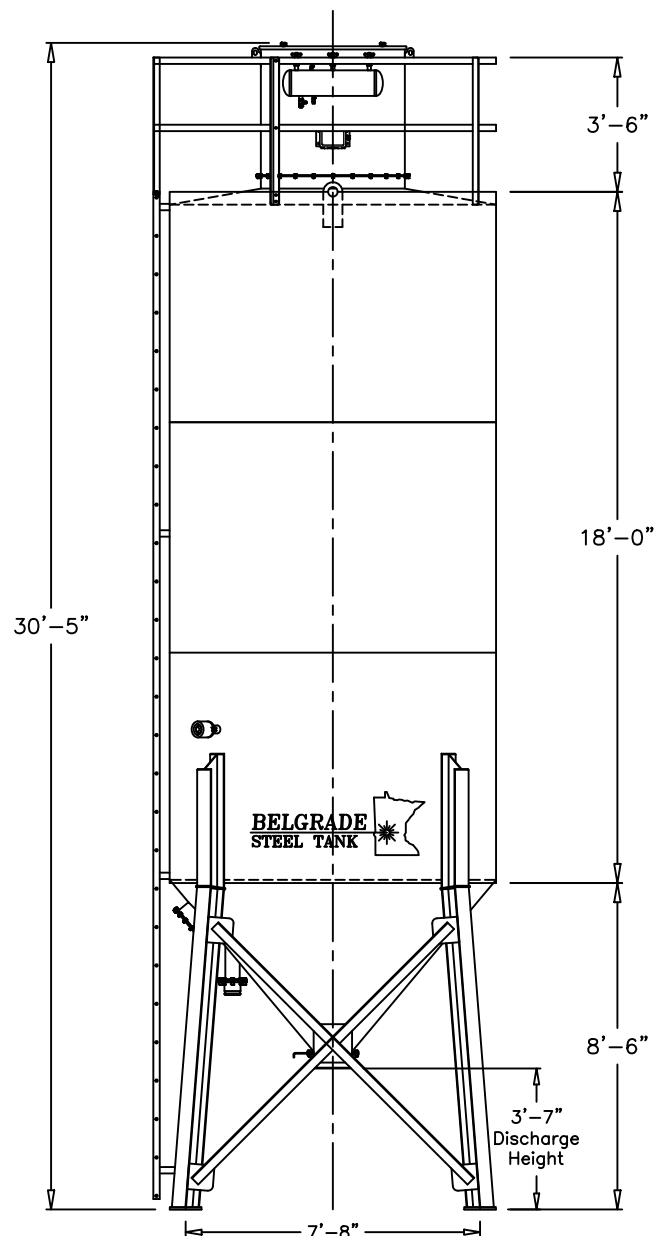
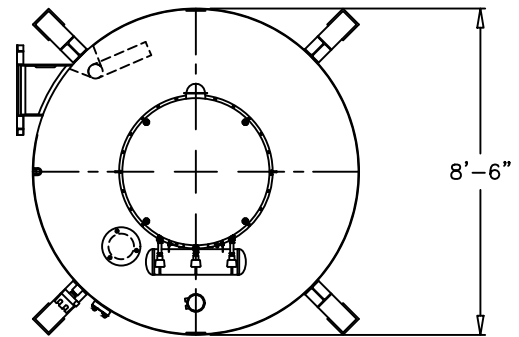

350 Barrel Basic Cement Silo

**BELGRADE
STEEL TANK**

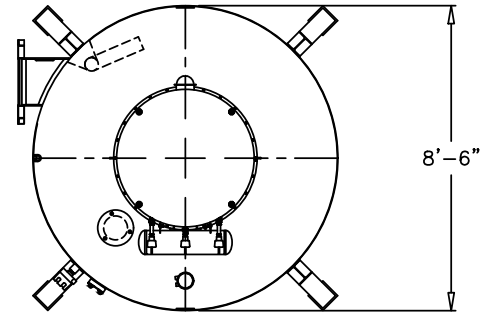

350 Barrel Basic Cement Silo

- 8'-6" Diameter x 36'-5" Overall Height
- 330 Sq. Ft. Pulse Jet Dust Collector
- Pressure Relief Valve
- 3'-8" Clearance Under Discharge
- Outside Ladder with OSHA Compliant Fall Arrest Cable System
- 4" Fill Pipe with Aluminum Adapter
- 20" Non-Pressurized Inspection Manhole
- Solimar Disc Package
- 10" Emergency Jam Gate
- Sandblast, Prime, and Paint
- Standard Colors:
 - RAL 7038 Gray, RAL 9010 White, RAL 1001 Tan, RAL 1032 Yellow

Options

- 150 Sq. Ft. Bag Area Dust Collector with Air Vibrator
- Bin Level Indicators
- Manual Air Valve Controls
- 10" or 12" Butterfly Valve
- 5" Fill Pipe
- 12" Emergency Jam Gate

Specifications

- Empty Weight 9,000#
- 1,400 Cu. Ft. Capacity
- 65 Ton Capacity (Cement)
- Part Number: BST350-86

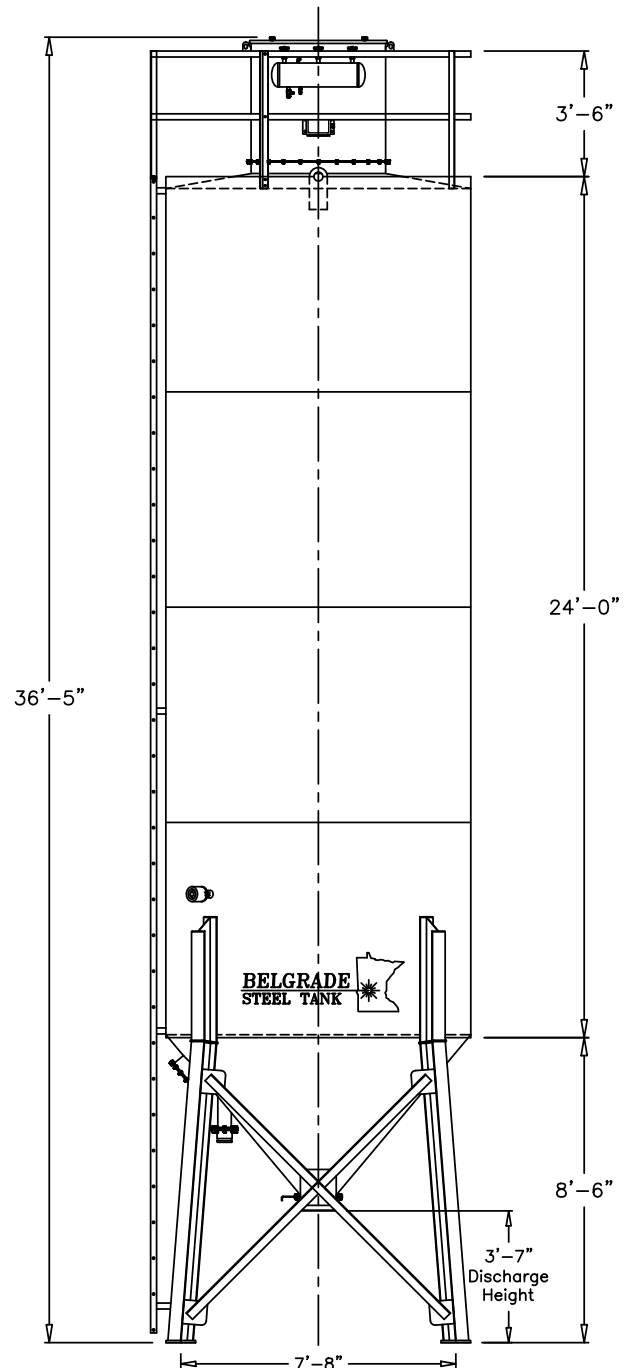

550 Barrel Basic Cement Silo

**BELGRADE
STEEL TANK**



550 Barrel Basic Cement Silo

- 12'-0" Diameter x 32'-8" Overall Height
- 330 Sq. Ft. Pulse Jet Dust Collector
- Pressure Relief Valve
- 3'-8" Clearance Under Discharge
- Outside Ladder with OSHA Compliant Fall Arrest Cable System
- 4" Fill Pipe with Aluminum Adapter
- 20" Non-Pressurized Inspection Manhole (High Level)
- 20" Non-Pressurized Inspection Manhole (Low Level)
- Solimar Disc Package
- 10" Emergency Jam Gate
- Sandblast, Prime, and Paint
- Standard Colors:
- RAL 7038 Gray, RAL 9010 White, RAL 1001 Tan, RAL 1032 Yellow

Options

- 150 Sq. Ft. Bag Area Dust Collector with Air Vibrator
- Bin Level Indicators
- Manual Air Valve Controls
- 10" or 12" Butterfly Valve
- 5" Fill Pipe
- 12" Emergency Jam Gate

Specifications

- Empty Weight 13,000#
- 2,200 Cu. Ft. Capacity
- 100 Ton Capacity (Cement)
- Part Number: BST550-120

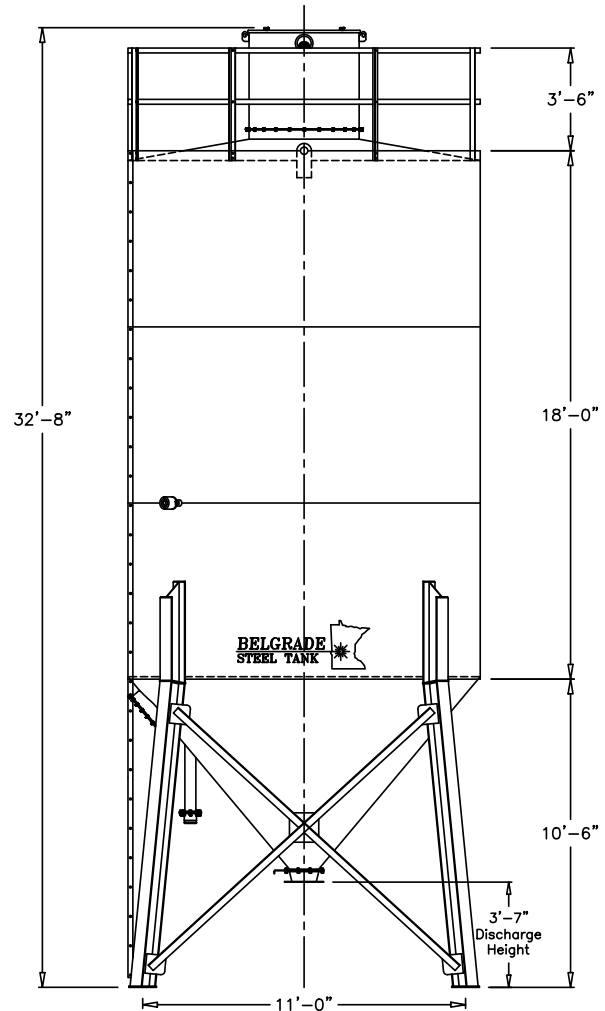
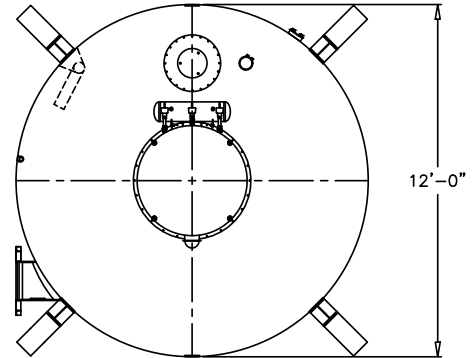

700 Barrel Basic Cement Silo

**BELGRADE
STEEL TANK**



700 Barrel Basic Cement Silo

- 12'-0" Diameter x 38'-8" Overall Height
- 330 Sq. Ft. Pulse Jet Dust Collector
- Pressure Relief Valve
- 3'-8" Clearance Under Discharge
- Outside Ladder with OSHA Compliant Fall Arrest Cable System
- 4" Fill Pipe with Aluminum Adapter
- 20" Non-Pressurized Inspection Manhole (High Level)
- 20" Non-Pressurized Inspection Manhole (Low Level)
- Solimar Disc Package
- 10" Emergency Jam Gate
- Sandblast, Prime, and Paint
- Standard Colors:
- RAL 7038 Gray, RAL 9010 White, RAL 1001 Tan, RAL 1032 Yellow

Options

- 150 Sq. Ft. Bag Area Dust Collector with Air Vibrator
- Bin Level Indicators
- Manual Air Valve Controls
- 10" or 12" Butterfly Valve
- 5" Fill Pipe
- 12" Emergency Jam Gate

Specifications

- Empty Weight 15,000#
- 2,800 Cu. Ft. Capacity
- 130 Ton Capacity (Cement)
- Part Number: BST700-120

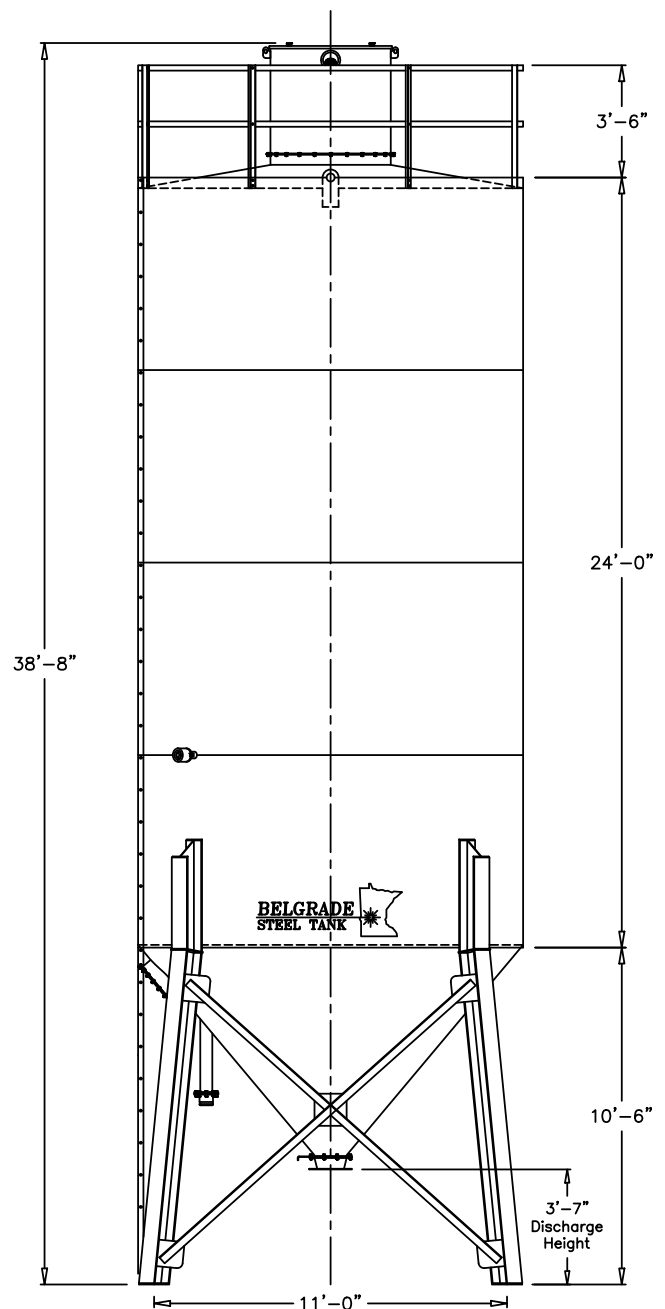
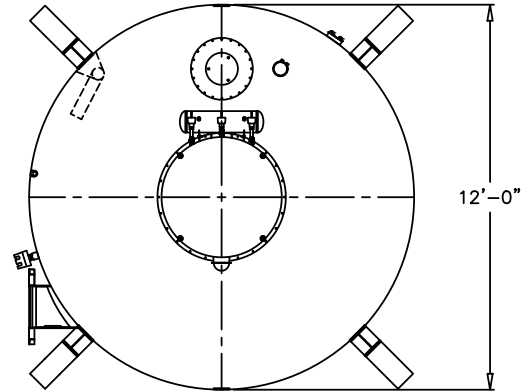

900 Barrel Basic Cement Silo

BELGRADE
STEEL TANK



900 Barrel Basic Cement Silo

- 12'-0" Diameter x 44'-8" Overall Height
- 330 Sq. Ft. Pulse Jet Dust Collector
- Pressure Relief Valve
- 3'-8" Clearance Under Discharge
- Outside Ladder with OSHA Compliant Fall Arrest Cable System
- 4" Fill Pipe with Aluminum Adapter
- 20" Non-Pressurized Inspection Manhole (High Level)
- 20" Non-Pressurized Inspection Manhole (Low Level)
- Solimar Disc Package
- 10" Emergency Jam Gate
- Sandblast, Prime, and Paint
- Standard Colors:
 - RAL 7038 Gray, RAL 9010 White, RAL 1001 Tan, RAL 1032 Yellow

Options

- 150 Sq. Ft. Bag Area Dust Collector with Air Vibrator
- Bin Level Indicators
- Manual Air Valve Controls
- 10" or 12" Butterfly Valve
- 5" Fill Pipe
- 12" Emergency Jam Gate

Specifications

- Empty Weight 17,000#
- 3,600 Cu. Ft. Capacity
- 168 Ton Capacity (Cement)
- Part Number: BST900-120

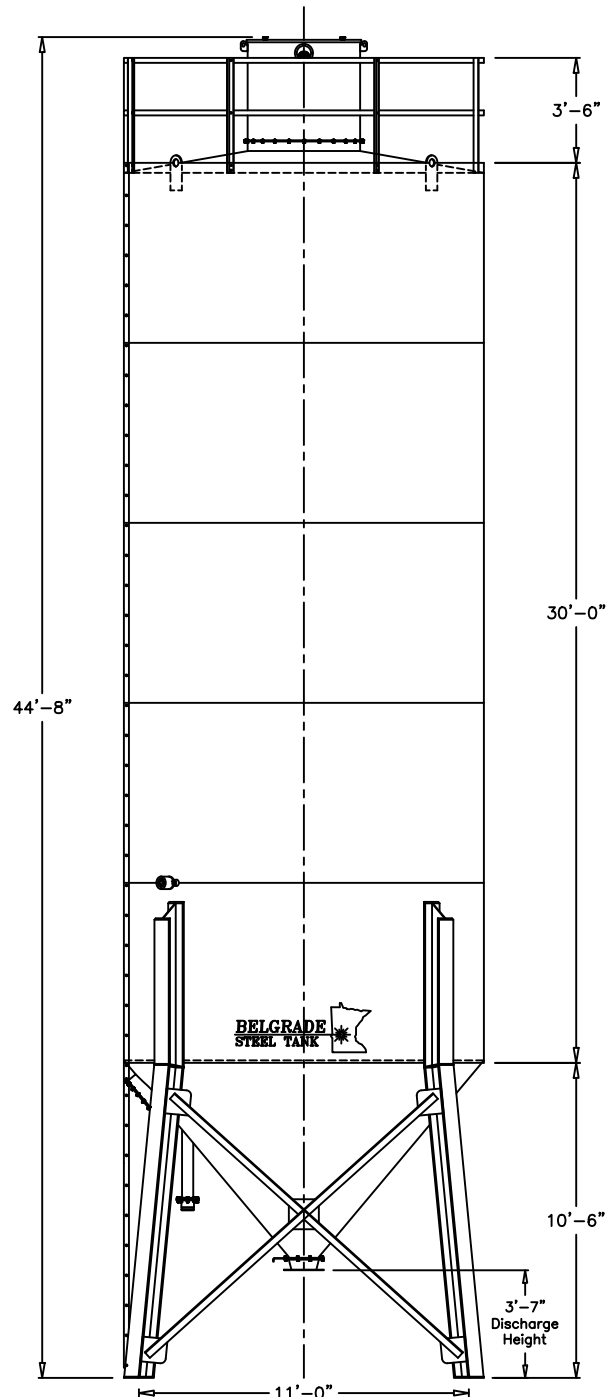
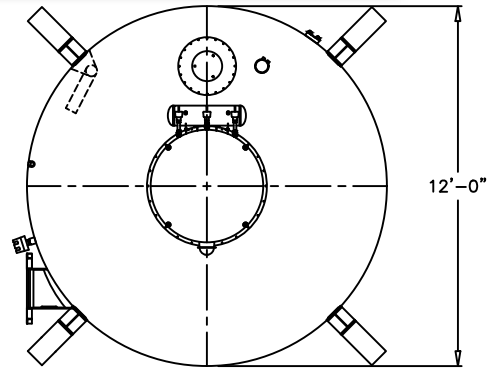

1050 Barrel Basic Cement Silo

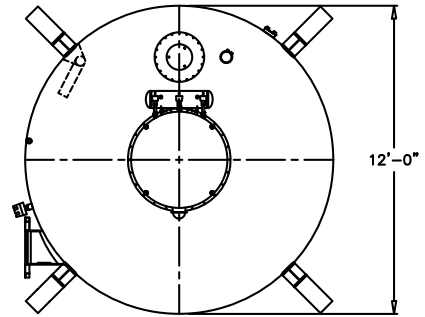

1050 Barrel Basic Cement Silo

- 12'-0" Diameter x 50'-8" Overall Height
- 330 Sq. Ft. Pulse Jet Dust Collector
- Pressure Relief Valve
- 3'-8" Clearance Under Discharge
- Outside Ladder with OSHA Compliant Fall Arrest Cable System
- 4" Fill Pipe with Aluminum Adapter
- 20" Non-Pressurized Inspection Manhole (High Level)
- 20" Non-Pressurized Inspection Manhole (Low Level)
- Solimar Disc Package
- 10" Emergency Jam Gate
- Sandblast, Prime, and Paint
- Standard Colors:
 - RAL 7038 Gray, RAL 9010 White, RAL 1001 Tan, RAL 1032 Yellow

Options

- 150 Sq. Ft. Bag Area Dust Collector with Air Vibrator
- Bin Level Indicators
- Manual Air Valve Controls
- 10" or 12" Butterfly Valve
- 5" Fill Pipe
- 12" Emergency Jam Gate

Specifications

- Empty Weight 21,000#
- 4,200 Cu. Ft. Capacity
- 196 Ton Capacity (Cement)
- Part Number: BST1050-120

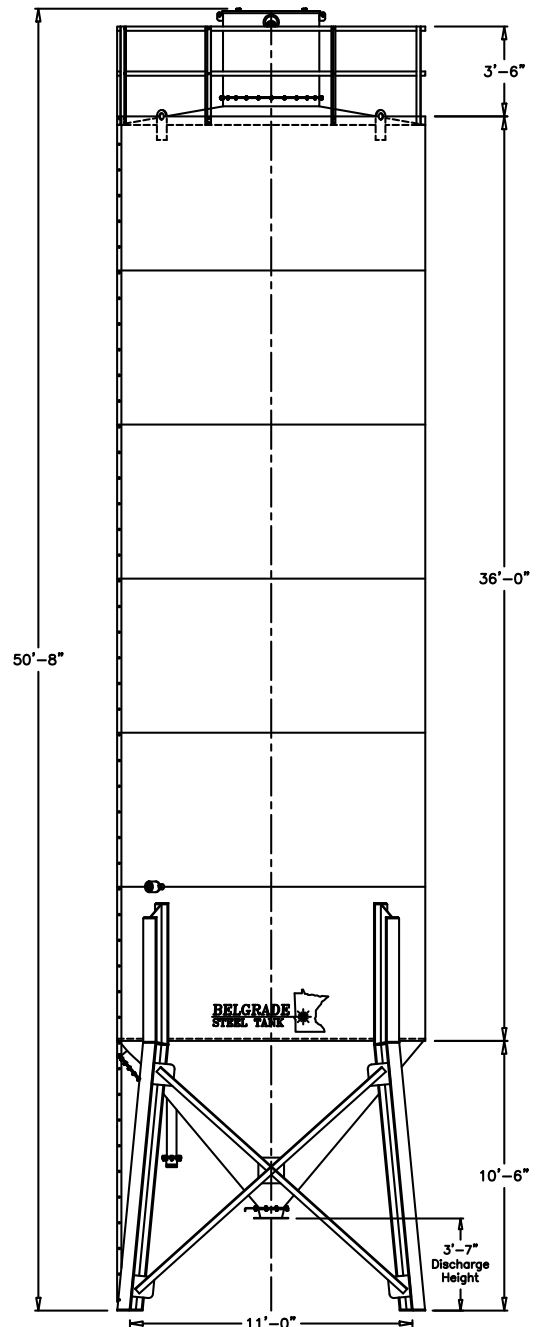

1200 Barrel Basic Cement Silo

**BELGRADE
STEEL TANK**

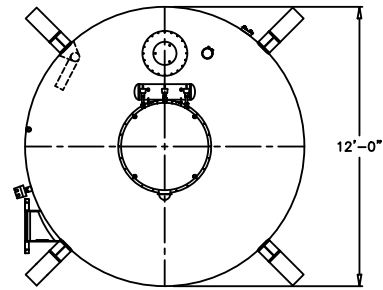

1200 Barrel Basic Cement Silo

- 12'-0" Diameter x 56'-8" Overall Height
- 330 Sq. Ft. Pulse Jet Dust Collector
- Pressure Relief Valve
- 3'-8" Clearance Under Discharge
- Outside Ladder with OSHA Compliant Fall Arrest Cable System
- 4" Fill Pipe with Aluminum Adapter
- 20" Non-Pressurized Inspection Manhole (High Level)
- 20" Non-Pressurized Inspection Manhole (Low Level)
- Solimar Disc Package
- 10" Emergency Jam Gate
- Sandblast, Prime, and Paint
- Standard Colors:
- RAL 7038 Gray, RAL 9010 White, RAL 1001 Tan, RAL 1032 Yellow

Options

- 150 Sq. Ft. Bag Area Dust Collector with Air Vibrator
- Bin Level Indicators
- Manual Air Valve Controls
- 10" or 12" Butterfly Valve
- 5" Fill Pipe
- 12" Emergency Jam Gate

Specifications

- Empty Weight 24,000#
- 4,800 Cu. Ft. Capacity
- 225 Ton Capacity (Cement)
- Part Number: BST1200-120

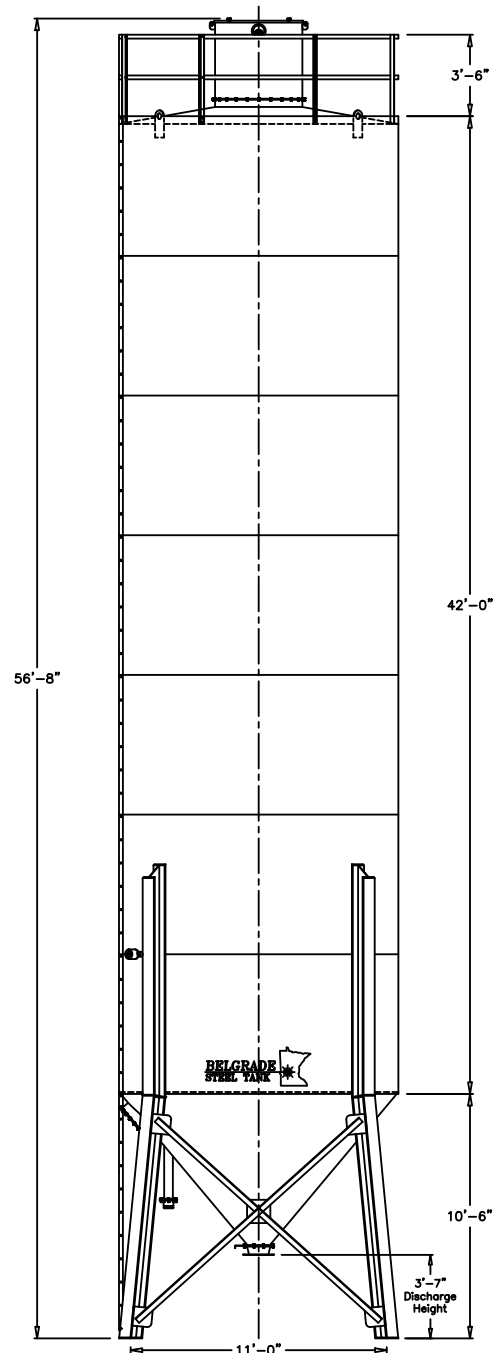

500 Barrel Split Cement Silo

**BELGRADE
STEEL TANK**



500 Barrel Split Silo

- 12'-0" Diameter x 32'-0" Overall Height
- (2) 330 Sq. Ft. Pulse Jet Dust Collectors
- (2) Pressure Relief Valves
- 3'-6" Clearance Under Discharge
- Outside Ladder with OSHA Compliant Fall Arrest Cable System
- (2) 4" Fill Pipes with Aluminum Adapters
- (2) 20" Non-Pressurized Inspection Manholes (High Level)
- (2) 20" Non-Pressurized Inspection Manholes (Low Level)
- (2) Solimar Disc Package
- (2) 10" Emergency Jam Gates
- Sandblast, Prime, and Paint
- Standard Colors:
- RAL 7038 Gray, RAL 9010 White, RAL 1001 Tan, RAL 1032 Yellow

Options

- 150 Sq. Ft. Bag Area Dust Collector with Air Vibrator
- Bin Level Indicators
- Manual Air Valve Controls
- 10" or 12" Butterfly Valve
- 5" Fill Pipe
- 33/66 or 50/50 Split Design
- 2'-0" or 3'-6" Discharge Center
- 12" Emergency Jam Gate

Specifications

- Empty Weight #18,000
- 2,000 Cu. Ft. Capacity
- 94 Ton Capacity (Cement)
- Part Number: BST500S-120

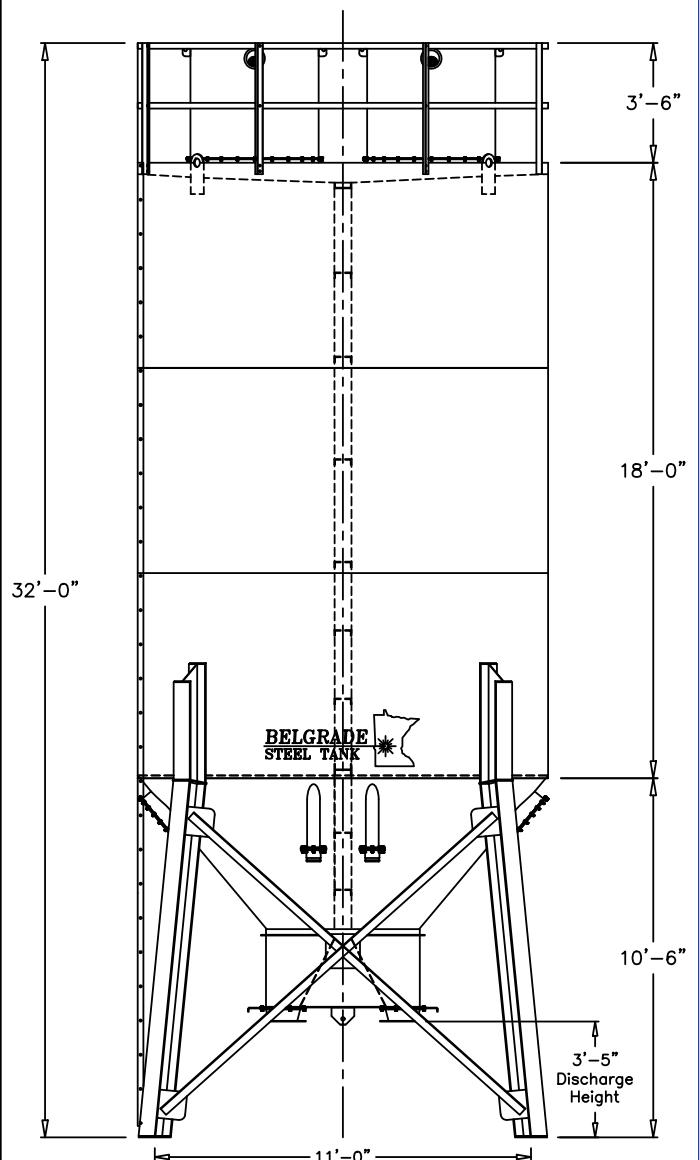
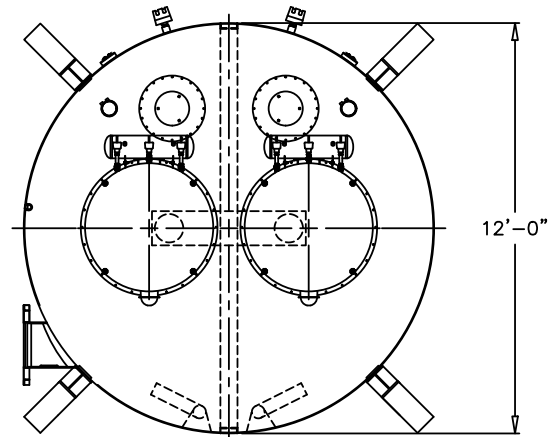

700 Barrel Split Cement Silo

**BELGRADE
STEEL TANK**



700 Barrel Split Silo

- 12'-0" Diameter x 38'-0" Overall Height
- (2) 330 Sq. Ft. Pulse Jet Dust Collectors
- (2) Pressure Relief Valves
- 3'-6" Clearance Under Discharge
- Outside Ladder with OSHA Compliant Fall Arrest Cable System
- (2) 4" Fill Pipes with Aluminum Adapters
- (2) 20" Non-Pressurized Inspection Manholes (High Level)
- (2) 20" Non-Pressurized Inspection Manholes (Low Level)
- (2) Solimar Disc Package
- (2) 10" Emergency Jam Gates
- Sandblast, Prime, and Paint
- Standard Colors: RAL 7038 Gray, RAL 9010 White, RAL 1001 Tan, RAL 1032 Yellow

Options

- 150 Sq. Ft. Bag Area Dust Collector with Air Vibrator
- Bin Level Indicators
- Manual Air Valve Controls
- 10" or 12" Butterfly Valve
- 5" Fill Pipe
- 33/66 or 50/50 Split Design
- 2'-0" or 3'-6" Discharge Center
- 12" Emergency Jam Gate

Specifications

- Empty Weight 21,500#
- 2,600 Cu. Ft. Capacity
- 122 Ton Capacity (Cement)
- Part Number: BST700S-120

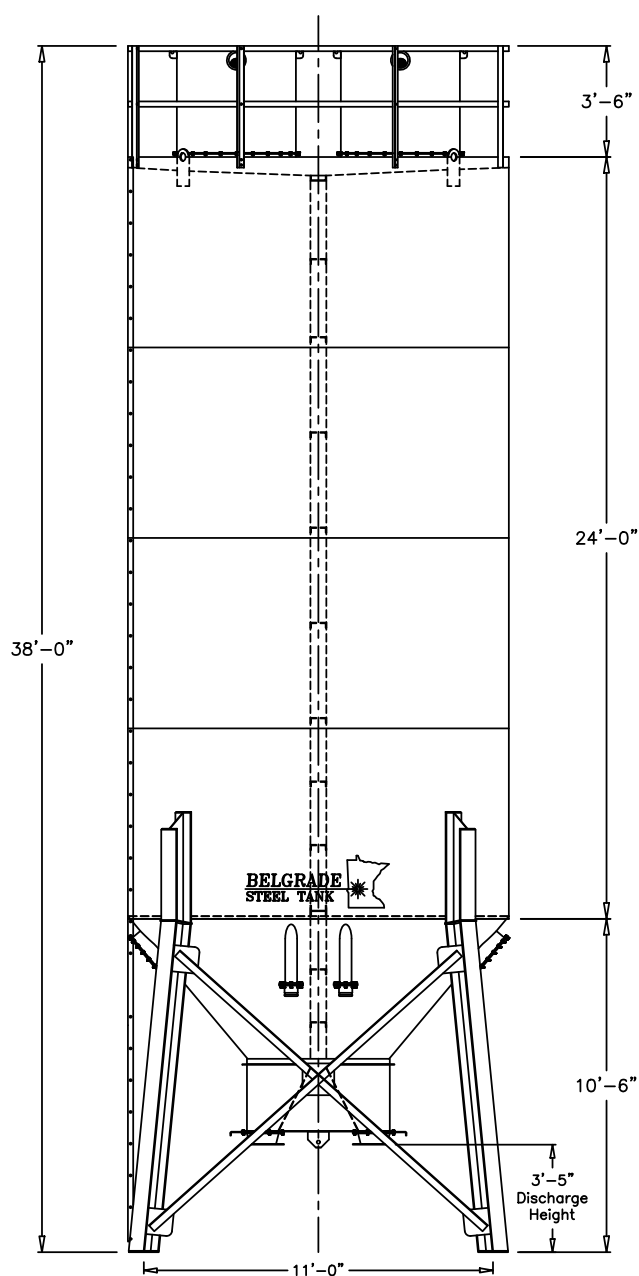
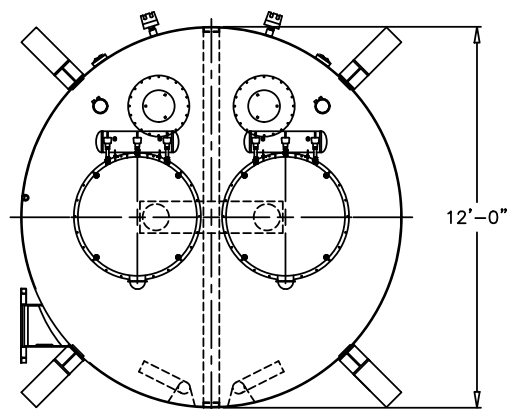

850 Barrel Split Cement Silo



850 Barrel Split Silo

- 12'-0" Diameter x 44'-0" Overall Height
- (2) 330 Sq. Ft. Pulse Jet Dust Collectors
- (2) Pressure Relief Valves
- 3'-6" Clearance Under Discharge
- Outside Ladder with OSHA Compliant Fall Arrest Cable System
- (2) 4" Fill Pipes with Aluminum Adapters
- (2) 20" Non-Pressurized Inspection Manholes (High Level)
- (2) 20" Non-Pressurized Inspection Manholes (Low Level)
- (2) Solimar Disc Package
- (2) 10" Emergency Jam Gates
- Sandblast, Prime, and Paint
- Standard Colors:
- RAL 7038 Gray, RAL 9010 White, RAL 1001 Tan, RAL 1032 Yellow

Options

- 150 Sq. Ft. Bag Area Dust Collector with Air Vibrator
- Bin Level Indicators
- Manual Air Valve Controls
- 10" or 12" Butterfly Valve
- 5" Fill Pipe
- 33/66 or 50/50 Split Design
- 2'-0" or 3'-6" Discharge Center
- 12" Emergency Jam Gate

Specifications

- Empty Weight 25,000#
- 3,400 Cu. Ft. Capacity
- 158 Ton Capacity (Cement)
- Part Number: BST850S-120

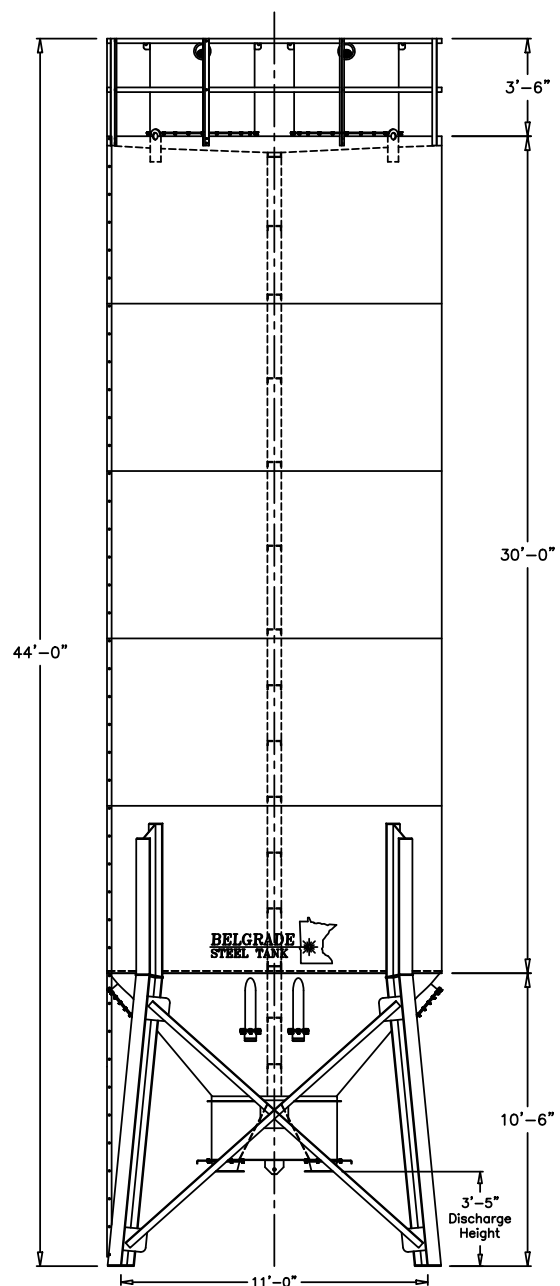
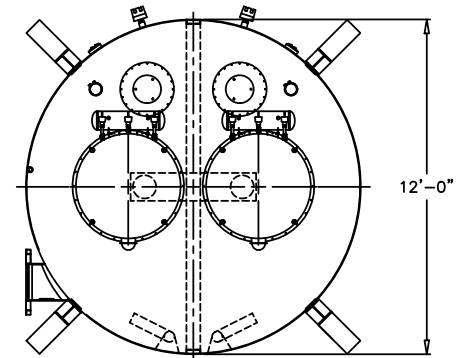

1000 Barrel Split Cement Silo

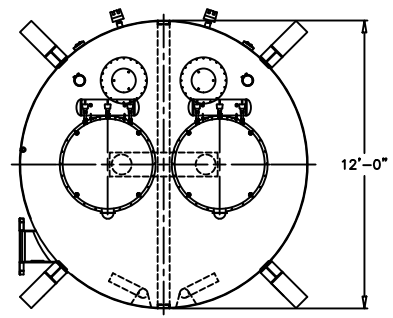

1000 Barrel Split Silo

- 12'-0" Diameter x 50'-0" Overall Height
- (2) 330 Sq. Ft. Pulse Jet Dust Collectors
- (2) Pressure Relief Valves
- 3'-6" Clearance Under Discharge
- Outside Ladder with OSHA Compliant Fall Arrest Cable System
- (2) 4" Fill Pipes with Aluminum Adapters
- (2) 20" Non-Pressurized Inspection Manholes (High Level)
- (2) 20" Non-Pressurized Inspection Manholes (Low Level)
- (2) Solimar Disc Package
- (2) 10" Emergency Jam Gates
- Sandblast, Prime, and Paint
- Standard Colors:
- RAL 7038 Gray, RAL 9010 White, RAL 1001 Tan, RAL 1032 Yellow

Options

- 150 Sq. Ft. Bag Area Dust Collector with Air Vibrator
- Bin Level Indicators
- Manual Air Valve Controls
- 10" or 12" Butterfly Valve
- 5" Fill Pipe
- 33/66 or 50/50 Split Design
- 2'-0" or 3'-6" Discharge Center
- 12" Emergency Jam Gate

Specifications

- Empty Weight 30,000#
- 4,000 Cu. Ft. Capacity
- 187 Ton Capacity (Cement)
- Part Number: BST1000S-120

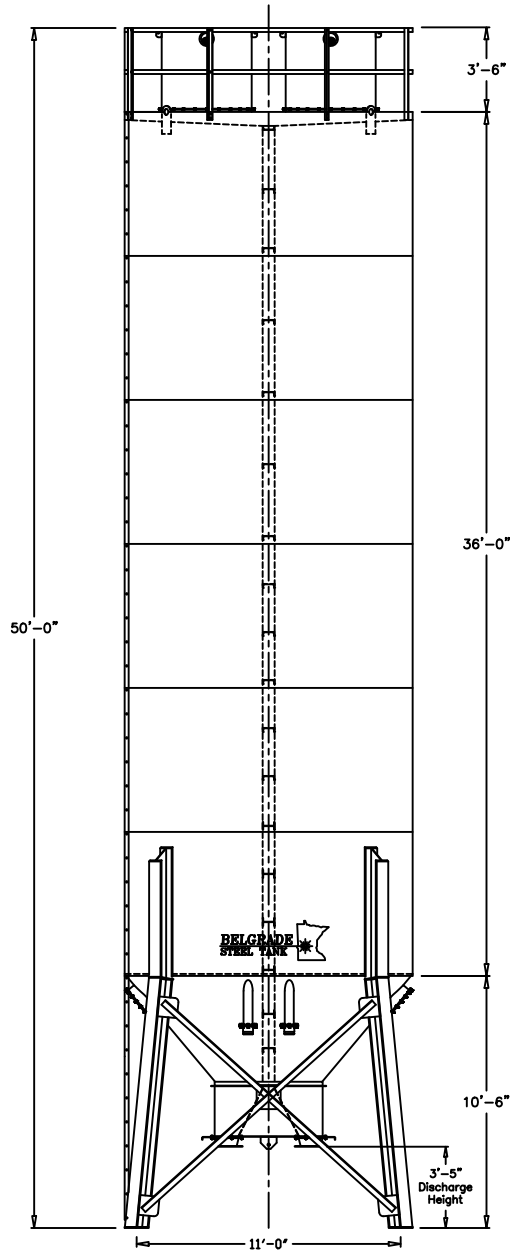

1200 Barrel Split Cement Silo

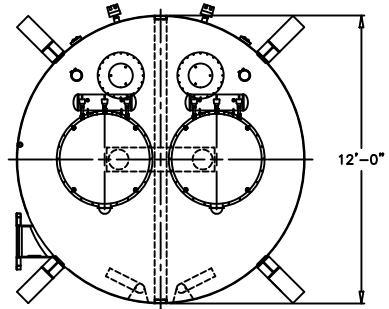

1200 Barrel Split Silo

- 12'-0" Diameter x 56'-0" Overall Height
- (2) 330 Sq. Ft. Pulse Jet Dust Collectors
- (2) Pressure Relief Valves
- 3'-6" Clearance Under Discharge
- Outside Ladder with OSHA Compliant Fall Arrest Cable System
- (2) 4" Fill Pipes with Aluminum Adapters
- (2) 20" Non-Pressurized Inspection Manholes (High Level)
- (2) 20" Non-Pressurized Inspection Manholes (Low Level)
- (2) Solimar Disc Packages
- (2) 10" Emergency Jam Gates
- Sandblast, Prime, and Paint
- Standard Colors:
 - RAL 7038 Gray, RAL 9010 White, RAL 1001 Tan, RAL 1032 Yellow

Options

- 150 Sq. Ft. Bag Area Dust Collector with Air Vibrator
- Bin Level Indicators
- Manual Air Valve Controls
- 10" or 12" Butterfly Valve
- 5" Fill Pipe
- 33/66 or 50/50 Split Design
- 2'-0" or 3'-6" Discharge Center
- 12" Emergency Jam Gate

Specifications

- Empty Weight 35,000#
- 4,600 Cu. Ft. Capacity
- 213 Ton Capacity (Cement)
- Part Number: BST1200S-120

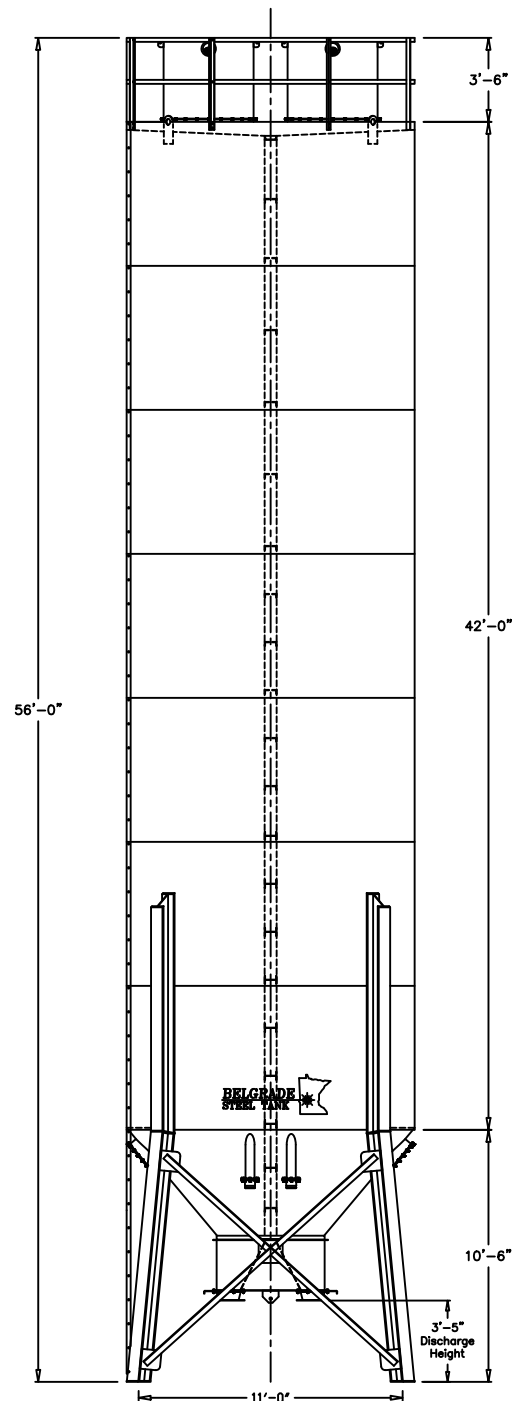

Belgrade Structural Stands

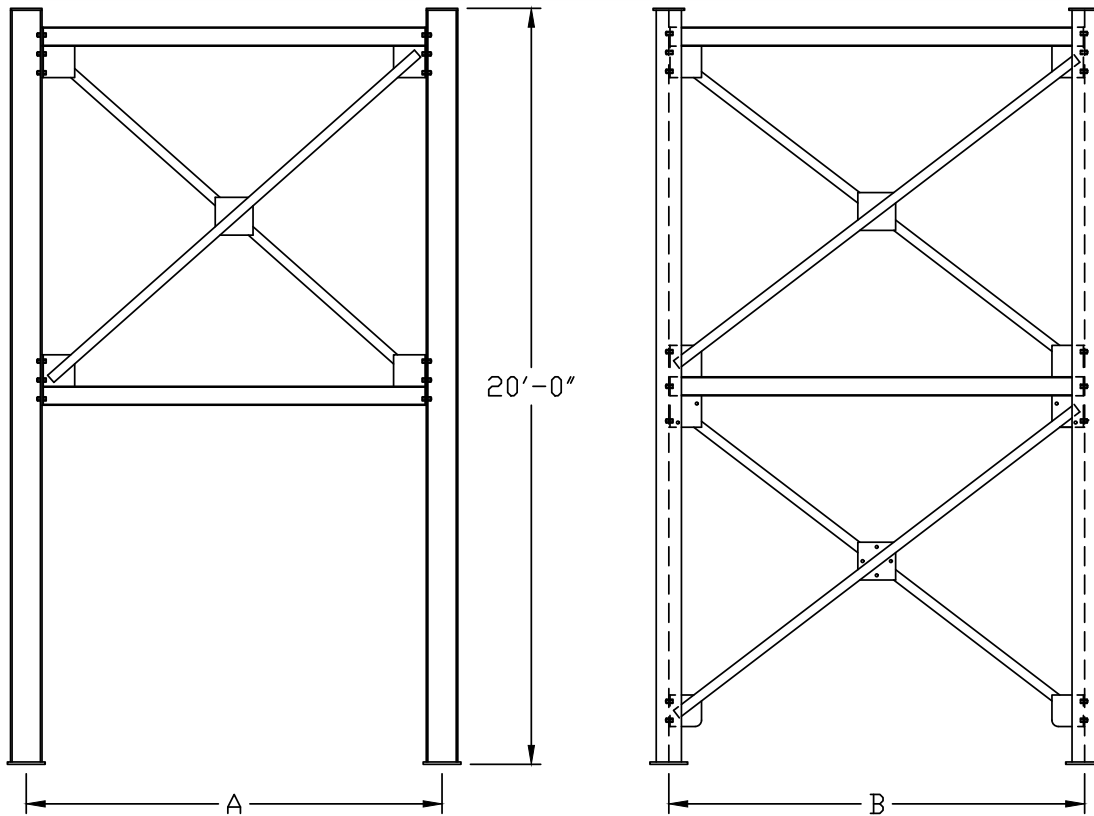

Non-Drive Thru Stands

- 20 Ft. Standard Height (Shorter or Taller May be Special Ordered)
- 4" Fill Pipe Extension
- Optional 5" Fill Pipe
- Outside Ladder with OSHA Compliant Fall Arrest Cable System
- Wide Flange Beam Columns and Horizontal Bracing with Angle Iron X-Bracing
- Minimal Bolted Assembly for Ease of Erection and Transportation
- Sandblast, Prime, and Paint
- Standard Colors:
- RAL 7038 Gray, RAL 9010 White, RAL 1001 Tan, RAL 1032 Yellow
- Optional Work Platform

Barrel	A	B	Weight
185	7'8"	7'8"	4,200#
270	7'8"	7'8"	4,200#
350	7'8"	7'8"	4,200#
550	11'0"	11'0"	4,800#
700	11'0"	11'0"	4,800#
900	11'0"	11'0"	7,500#
1050	11'0"	11'0"	7,500#
1200	11'0"	11'0"	7,500#
700 Split	11'0"	11'0"	7,500#
850 Split	11'0"	11'0"	7,500#
1000 Split	11'0"	11'0"	7,500#
1200 Split	11'0"	11'0"	7,500#

Belgrade Structural Stands

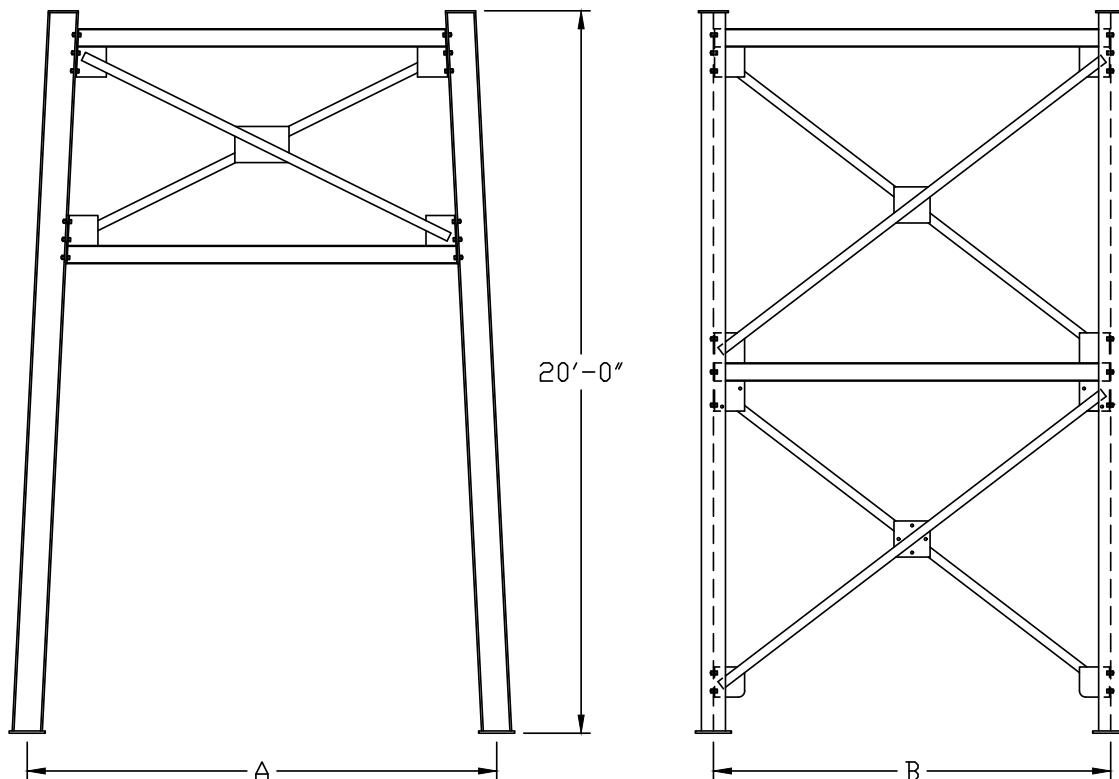

Drive Thru Stands

- 20 Ft. Standard Height (Shorter or Taller May be Special Ordered)
- 4" Fill Pipe Extension
Optional 5" Fill Pipe
- Outside Ladder with OSHA Compliant Fall Arrest Cable System
- Wide Flange Beam Columns and Horizontal Bracing with Angle Iron X-Bracing
- Minimal Bolted Assembly for Ease of Erection and Transportation
- Sandblast, Prime, and Paint
- Standard Colors:
- RAL 7038 Gray, RAL 9010 White, RAL 1001 Tan, RAL 1032 Yellow
- Optional Work Platform

Barrel	A	B	Weight
185	13'0"	7'8"	4,200#
270	13'0"	7'8"	4,200#
350	13'0"	7'8"	4,200#
550	13'0"	11'0"	4,800#
700	13'0"	11'0"	4,800#
900	13'0"	11'0"	7,500#
1050	13'0"	11'0"	7,500#
1200	13'0"	11'0"	7,500#
700 Split	13'0"	11'0"	7,500#
850 Split	13'0"	11'0"	7,500#
1000 Split	13'0"	11'0"	7,500#
1200 Split	13'0"	11'0"	7,500#

Belgrade Portable Cement Silos



350 Portable Silo

200 Low Profile Silo



1050 Portable Silo



375 Low Profile Silo

Table of Contents

270 Barrel Round Portable Silo 22

350 Barrel Round Portable Silo 24

550 Barrel Round Portable Silo 26

700 Barrel Round Portable Silo 28

900 Barrel Round Portable Silo 30

1050 Barrel Round Portable Silo 32

1200 Barrel Round Portable Silo 34

500 Barrel Round Portable Split Silo..... 36

700 Barrel Round Portable Split Silo..... 38

850 Barrel Round Portable Split Silo..... 40

200 Barrel Low Profile Silo..... 42

375 Barrel Low Profile Silo..... 44

270 Barrel Round Portable Silo



270 Barrel Round Portable Silo

- 8'-6" Diameter x 33'-3" Overall Height
- Positive Feed Drive Auger System
- 8" Diameter x 17'-0" Internal Auger
- 5 HP Motor and Gear Box Drive
- Heavy Duty Dual Axle Trailer and Tires
- Electric Brakes and Lights Package
- 330 Sq. Ft. Pulse Jet Dust Collector
- Pressure Relief Valve
- Single Speed Trailer Jack
- 13'-7" Auger Discharge Height
- Outside Ladder with OSHA Compliant Fall Arrest Cable System
- 4" Fill Pipe with Aluminum Adapter
- 20" Non-Pressurized Inspection Manhole
- Solimar Disc Package
- Sandblast, Prime, and Paint
- Standard Colors:
RAL 7038 Gray, RAL 9010 White,
RAL 1001 Tan, RAL 1032 Yellow

Options

- 150 Sq. Ft. Dust Collector
- Bin Level Indicators
- Single Phase Motor
- Hydraulic Drive Motor with Flow Controls and Quick Connects
- 16 HP Gas Motor
- Motor Starter Controls
- Manual Air Valve Controls
- Upgrade to 10" or 12" Internal Auger
- 5" Fill Pipe

Specifications

- Empty Weight 8,500#
- Hitch Weight 1,400#
- 1,080 Cu. Ft. Capacity
- 50 Ton Capacity (Cement)
- Output Capacity Approximately 7 Cu. Ft. Per Minute (7" Screw Conveyor)
- Part Number: BST270P-RD-EB

**BELGRADE
STEEL TANK**



270 Barrel Round Portable Silo

Positive Feed Drive System

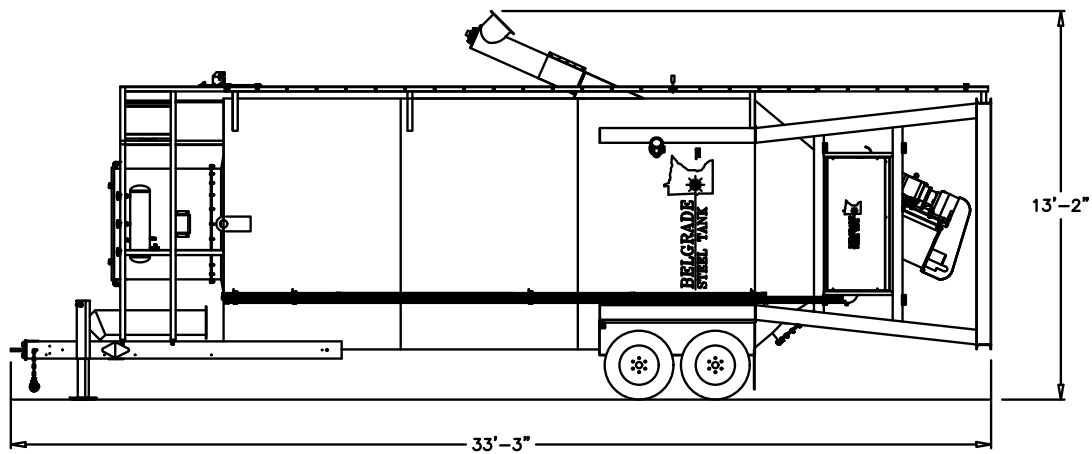
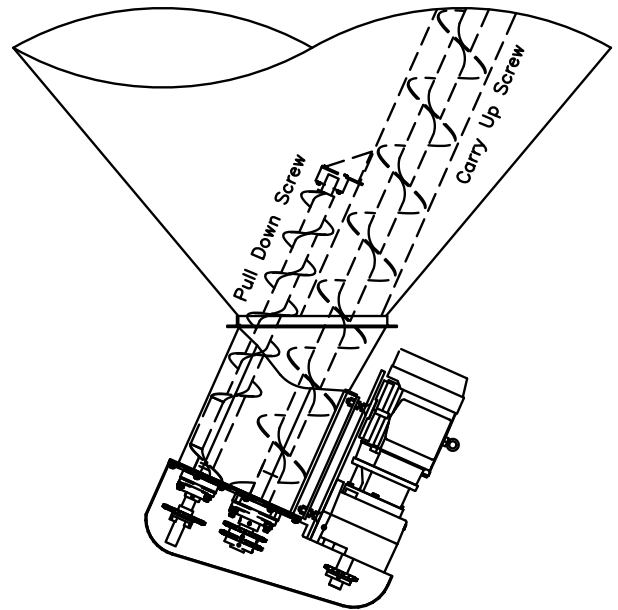
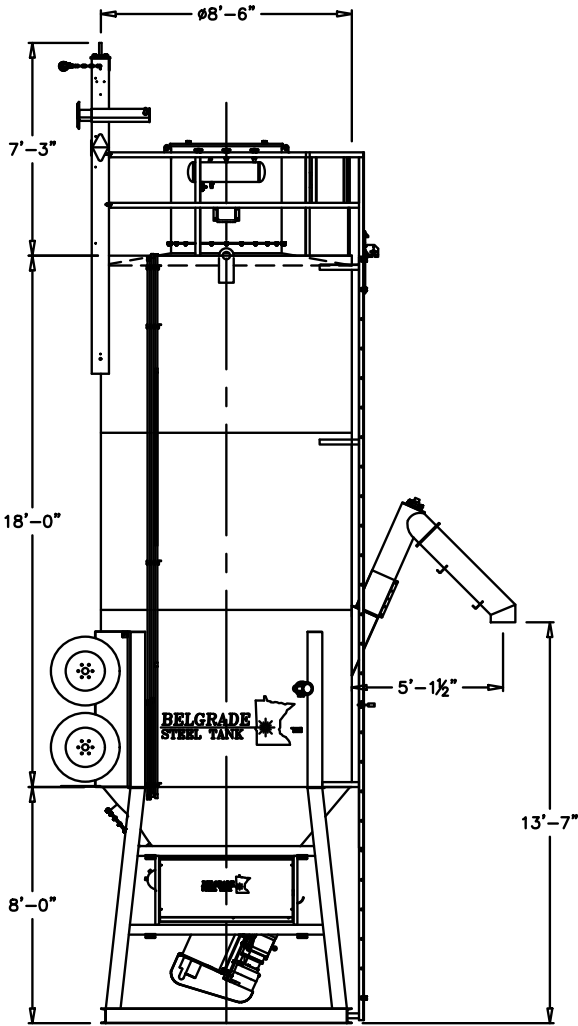

350 Barrel Round Portable Silo



350 Barrel Round Portable Silo

- 8'-6" Diameter x 39'-2 1/2" Overall Height
- Positive Feed Drive Auger System
- 10" Diameter Auger x 17'-0" Internal Auger
- 10 HP Motor and Gear Box Drive
- Heavy Duty Dual Axle Trailer and Tires
- Electric Brakes and Lights Package
- 330 Sq. Ft. Pulse Jet Dust Collector
- Pressure Relief Valve
- Single Speed Trailer Jack
- 13'-6" Auger Discharge Height
- Outside Ladder with OSHA Compliant Fall Arrest Cable System
- 4" Fill Pipe with Aluminum Adapter
- Non-Pressurized Inspection Manhole
- Solimar Disc Package
- Sandblast, Prime, and Paint
- Standard Colors:
RAL 7038 Gray, RAL 9010 White,
RAL 1001 Tan, RAL 1032 Yellow

Options

- 150 Sq. Ft. Dust Collector
- Bin Level Indicators
- Single Phase Motor
- Hydraulic Drive Motor with Flow Controls and Quick Connectors
- Motor Starter Controls
- Manual Air Valve Controls
- Upgrade to 12" Internal Auger
- 5" Fill Pipe

Specifications

- Empty Weight 10,000#
- Hitch Weight 2,100#
- 1,400 Cu. Ft. Capacity
- 65 Ton Capacity (Cement)
- Output Capacity Approximately 15 Cu. Ft. Per Minute (9" Screw Conveyor)
- Part Number: BST350P-RD-EB

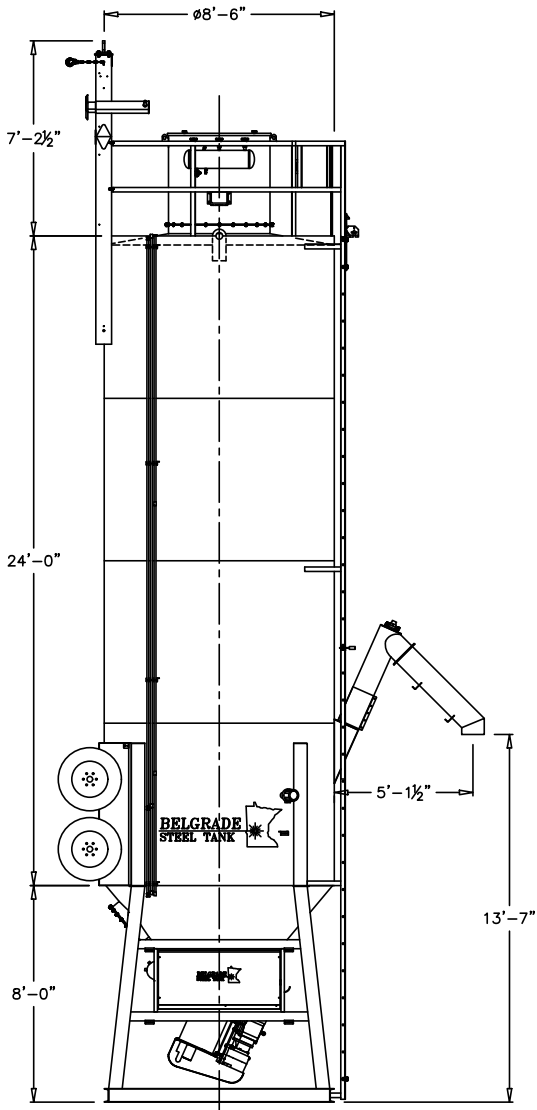

350 Barrel Round Portable Silo

Positive Feed Drive System

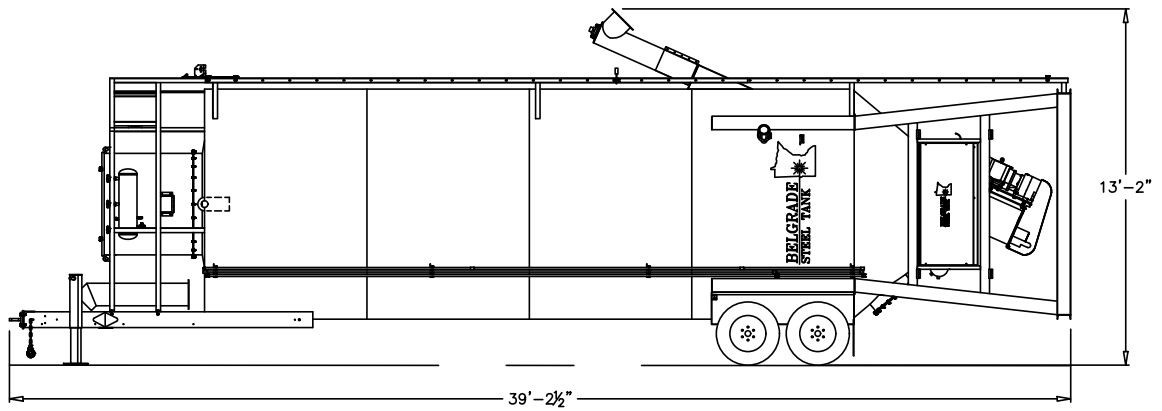
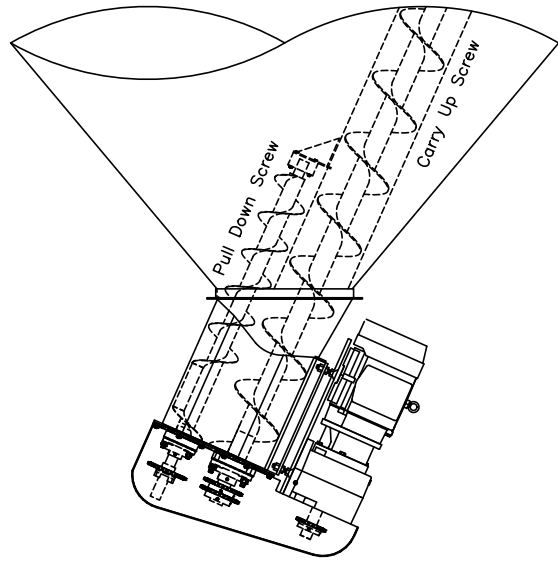

550 Barrel Round Portable Silo



550 Barrel Round Portable Silo

- 12'-0" Diameter x 37'-4" Overall Height
- Positive Feed Drive Auger System
- 10" x 17'-6" Internal Auger
- 10 HP Motor and Gear Box Drive
- Heavy Duty Dual Axle Trailer and Tires
- Electric Brakes and Lights Package
- 330 Sq. Ft. Pulse Jet Dust Collector
- Pressure Relief Valve
- Two Speed Trailer Jack Set
- 15'-7" Auger Discharge Height
- Outside Ladder with OSHA Compliant Fall Arrest Cable System
- 4" Fill Pipe with Aluminum Adapter
- 20" Non-Pressurized Inspection Manhole (High Level)
- 20" Non-Pressurized Inspection Manhole (Low Level)
- Solimar Disc Package
- Sandblast, Prime, and Paint
- Standard Colors:
RAL 7038 Gray, RAL 9010 White,
RAL 1001 Tan, RAL 1032 Yellow

Options

- 150 Sq. Ft. Dust Collector
- Bin Level Indicators
- Single Phase Motor
- Hydraulic Drive Motor
- Motor Starter Controls
- Manual Air Valve Controls
- Upgrade to 12" Internal Auger
- 5" Fill Pipe

Specifications

- Empty Weight 14,300#
- Hitch Weight 5,400#
- 2,200 Cu. Ft. Capacity
- 100 Ton Capacity (Cement)
- Output Capacity Approximately 15 Cu. Ft. Per Minute (9" Screw Conveyor)
- Part Number: BST550P-RD-AB

BELGRADE
STEEL TANK



550 Barrel Round Portable Silo

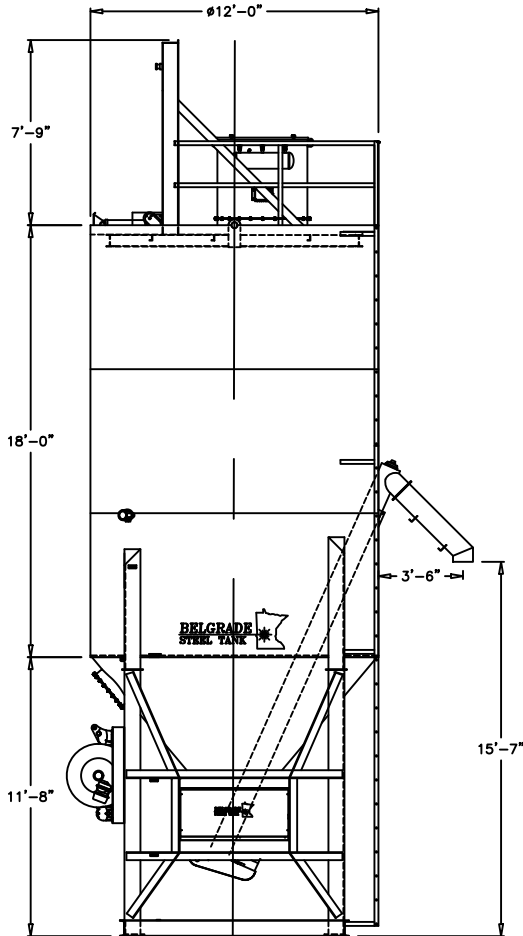

Positive Feed Drive System

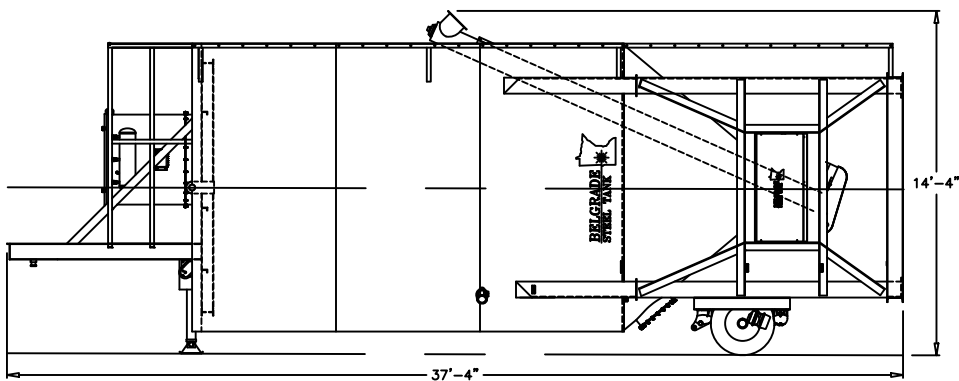
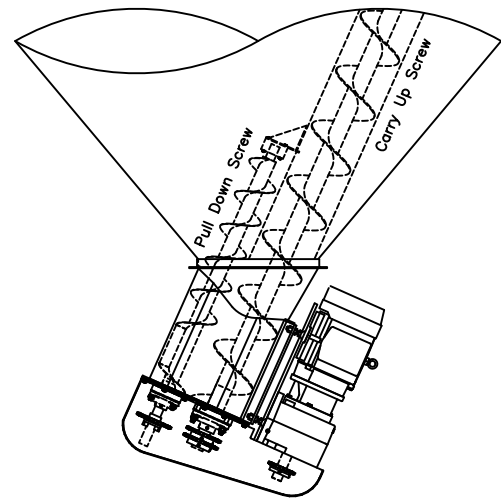

700 Barrel Round Portable Silo



700 Barrel Round Portable Silo

- 12'-0" Diameter x 43'-4" Overall Height
- Positive Feed Drive Auger System
- 10" Diameter x 17'-6" Internal Auger
- 10 HP Motor and Gear Box Drive
- Heavy Duty Dual Axle Trailer and Tires
- Air Brakes and Lights Package
- 330 Sq. Ft. Pulse Jet Dust Collector
- Pressure Relief Valve
- Two Speed Trailer Jack Set
- 14'-5" Auger Discharge Height
- Outside Ladder with OSHA Compliant Fall Arrest Cable System
- 4" Fill Pipe with Aluminum Adapter
- 20" Non-Pressurized Inspection Manhole (High Level)
- 20" Non-Pressurized Inspection Manhole (Low Level)
- Solimar Disc Package
- Sandblast, Prime, and Paint
- Standard Colors:
RAL 7038 Gray, RAL 9010 White,
RAL 1001 Tan, RAL 1032 Yellow

Options

- 150 Sq. Ft. Dust Collector
- Bin Level Indicators
- Single Phase Motor
- Hydraulic Drive Motor with Flow Controls and Quick Connects
- Motor Starter Controls
- Manual Air Valve Controls
- Upgrade to 12" Internal Auger
- 5" Fill Pipe

Specifications

- Empty Weight 18,800#
- Hitch Weight 7,500#
- 2,800 Cu. Ft. Capacity
- 130 Ton Capacity (Cement)
- Output Capacity Approximately 15 Cu. Ft. Per Minute (9" Screw Conveyor)
- Part Number: BST700P-RD-AB

**BELGRADE
STEEL TANK**



700 Barrel Round Portable Silo

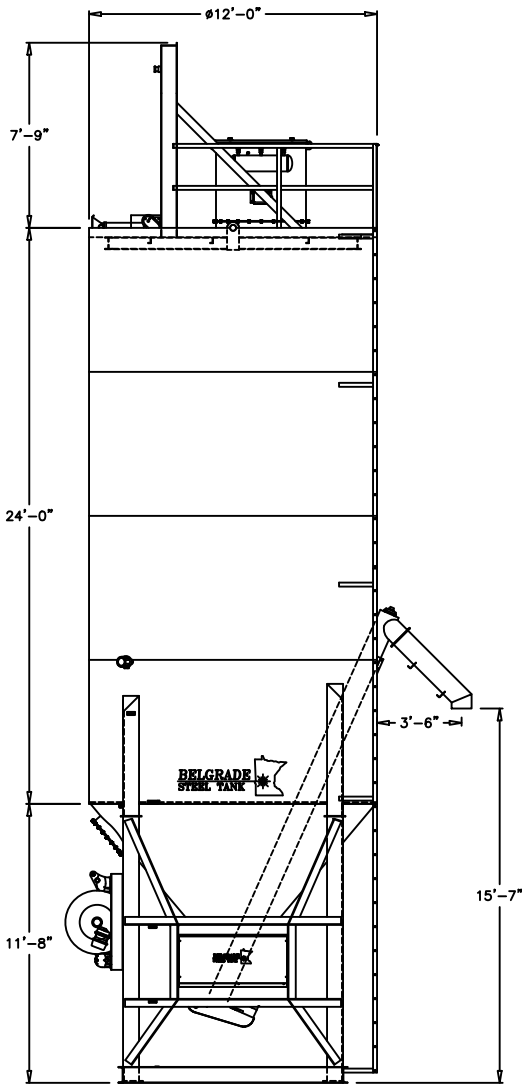

Positive Feed Drive System

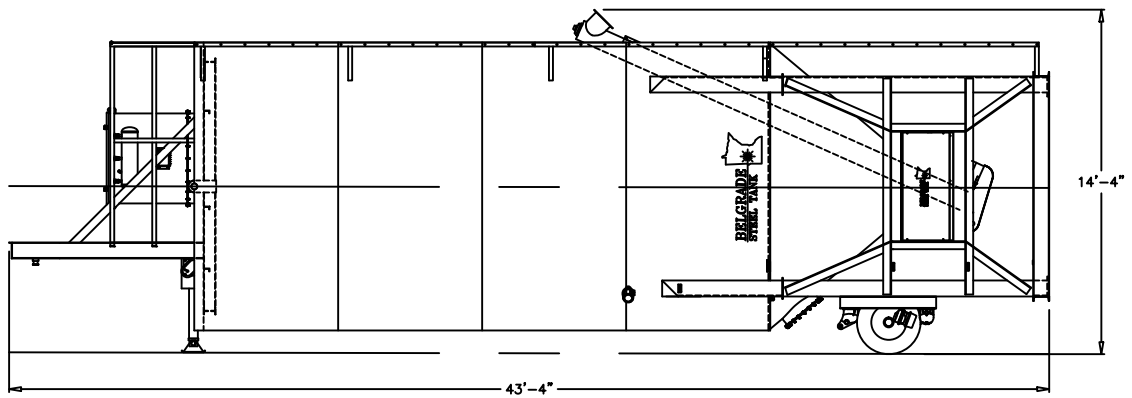
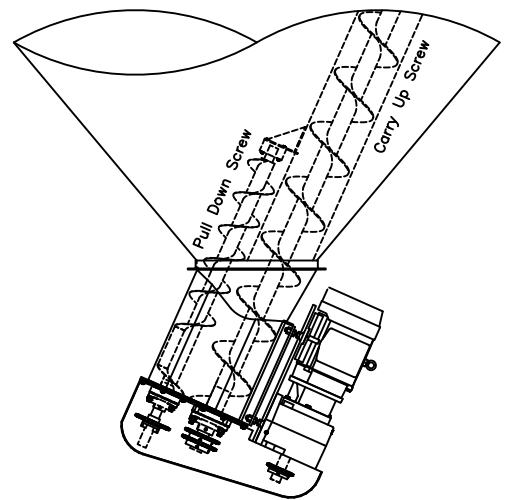

900 Barrel Round Portable Silo



900 Barrel Round Portable Silo

- 12'-0" Diameter x 47'-7" Overall Height
- Positive Feed Drive Auger System
- 10" Diameter x 17'-6" Internal Auger
- 10 HP Motor and Gear Box Drive
- Heavy Duty Dual Axle Trailer and Tires
- Air Brakes and Lights Package
- 330 Sq. Ft. Pulse Jet Dust Collector
- Pressure Relief Valve
- Two Speed Trailer Jack Set
- 14'-5" Auger Discharge Height
- Outside Ladder with OSHA Compliant Fall Arrest Cable System
- 4" Fill Pipe with Aluminum Adapter
- 20" Non-Pressurized Inspection Manhole (High Level)
- 20" Non-Pressurized Inspection Manhole (Low Level)
- Solimar Disc Package
- Sandblast, Prime, and Paint
- Standard Colors:
RAL 7038 Gray, RAL 9010 White,
RAL 1001 Tan, RAL 1032 Yellow

Options

- 150 Sq. Ft. Dust Collector
- Bin Level Indicators
- Single Phase Motor
- Hydraulic Drive Motor with Flow Control and Quick Connects
- Motor Starter Controls
- Manual Air Valve Controls
- Upgrade to 12" Internal Auger
- 5" Fill Pipe

Specifications

- Empty Weight 20,600#
- Hitch Weight 8,100#
- 3,600 Cu. Ft. Capacity
- 170 Ton Capacity (Cement)
- Output Capacity Approximately 15 Cu. Ft. Per Minute (9" Screw Conveyor)
- Part Number: BST900P-RD-AB

BELGRADE
STEEL TANK



900 Barrel Round Portable Silo

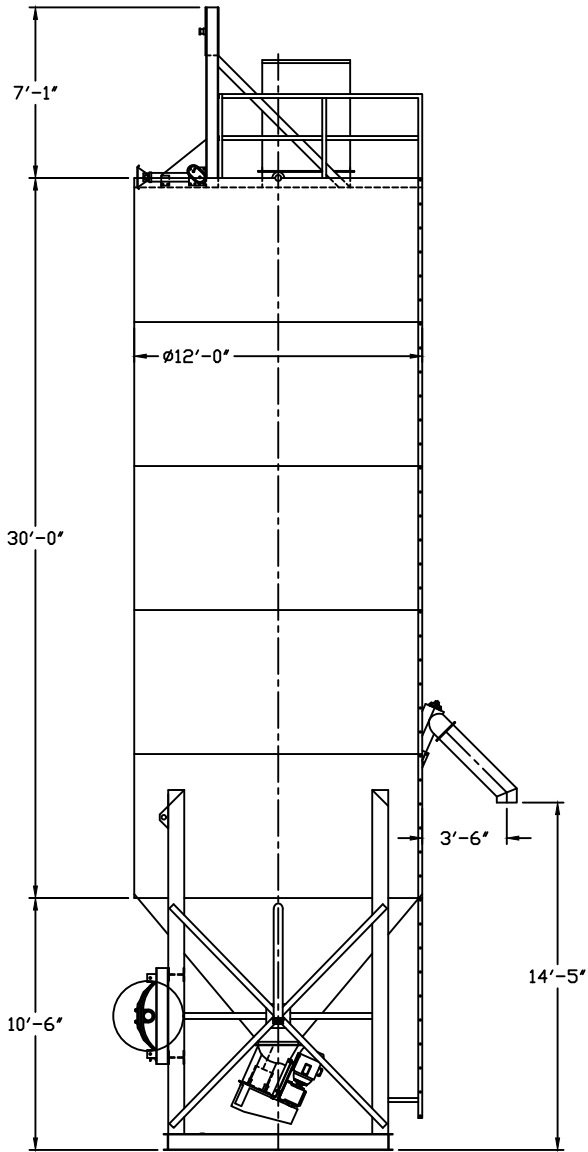

Positive Feed Drive System

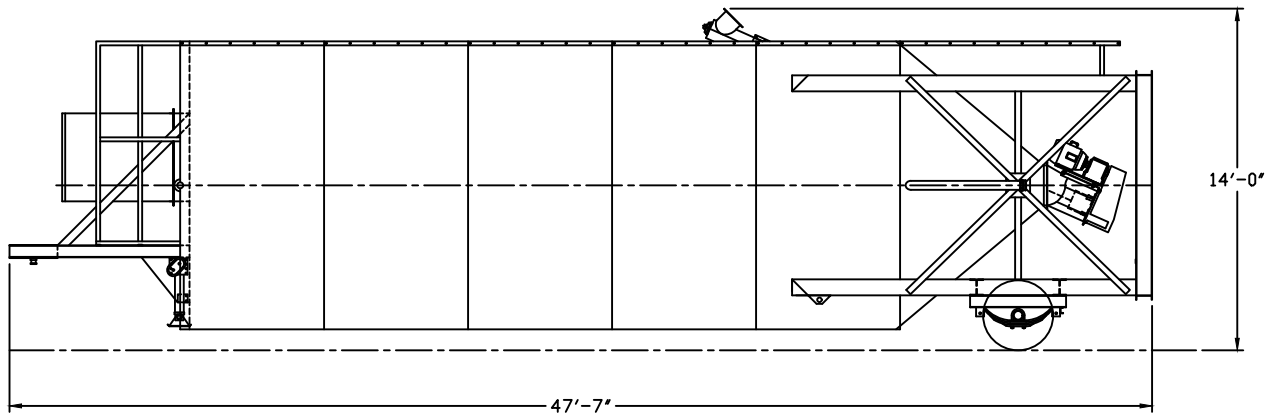
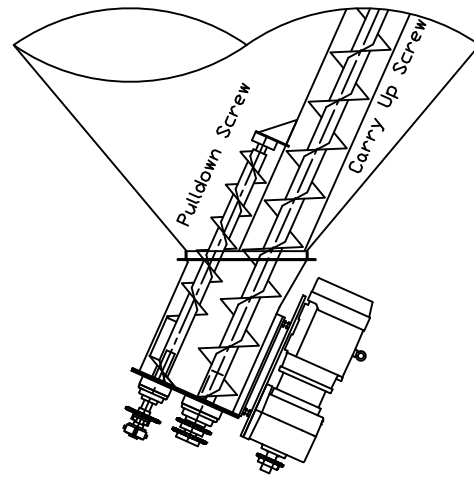

1050 Barrel Round Portable Silo



1050 Barrel Round Portable Silo

- 12'-0" Diameter x 55'-4" Overall Height
- Positive Feed Drive Auger System
- 12" Diameter x 17'-6" Internal Auger
- 20 HP Motor and Gear Box Drive
- Heavy Duty Dual Axle Trailer and Tires
- Air Brakes and Lights Package
- 330 Sq. Ft. Pulse Jet Dust Collector
- Pressure Relief Valve
- Two Speed Trailer Jack Set
- 15'-7" Auger Discharge Height
- Outside Ladder with OSHA Compliant Fall Arrest Cable System
- 4" Fill Pipe with Aluminum Adapter
- 20" Non-Pressurized Inspection Manhole (High Level)
- 20" Non-Pressurized Inspection Manhole (Low Level)
- Solimar Disc Package
- Sandblast, Prime, and Paint
- Standard Colors:
RAL 7038 Gray, RAL 9010 White,
RAL 1001 Tan, RAL 1032 Yellow

Options

- 150 Sq. Ft. Dust Collector
- Bin Level Indicators
- Motor Starter Controls
- Manual Air Valve Controls
- 5" Fill Pipe

Specifications

- Empty Weight 22,400#
- Hitch Weight 8,900#
- 4,200 Cu. Ft. Capacity
- 200 Ton Capacity (Cement)
- Output Capacity Approximately 30 Cu. Ft. Per Minute (12" Screw Conveyor)
- Part Number: BST1050P-RD-AB

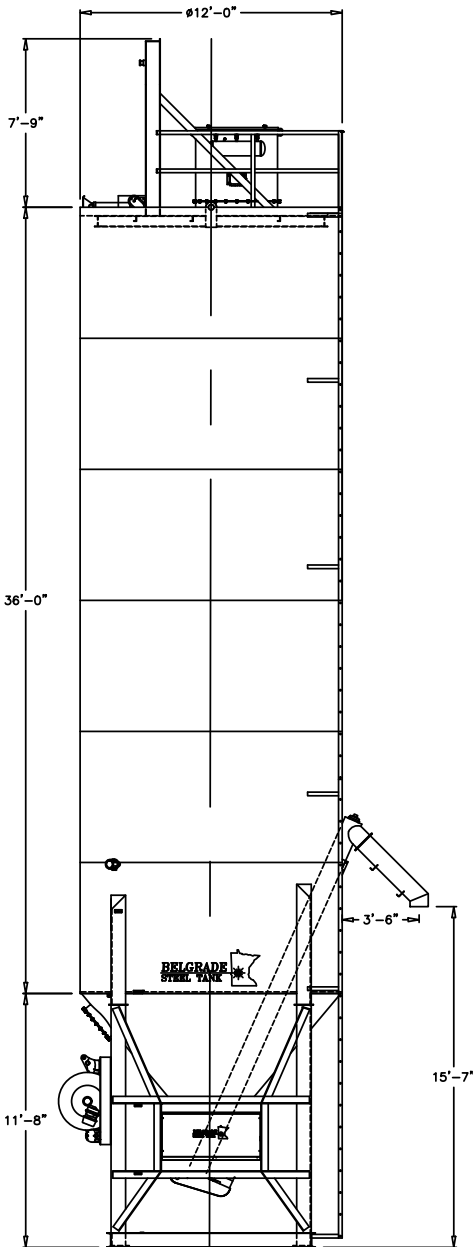

1050 Barrel Round Portable Silo

Positive Feed Drive System

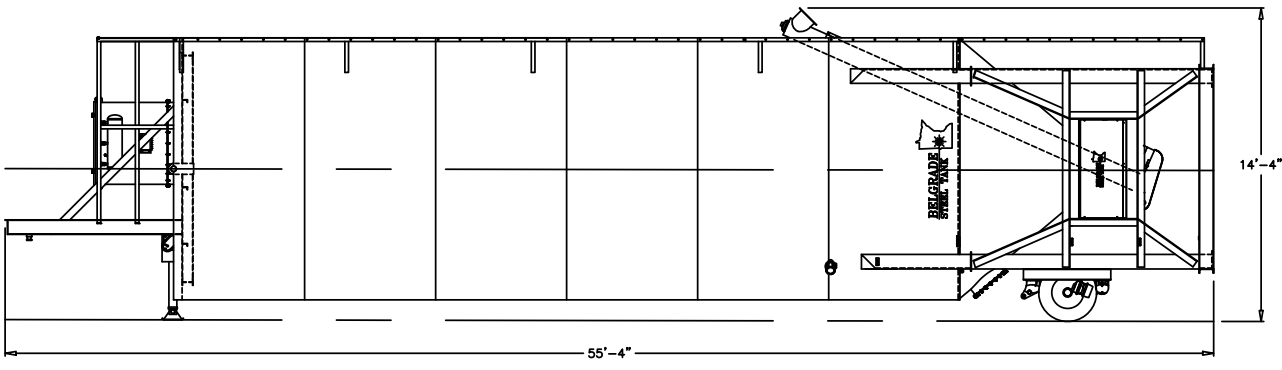
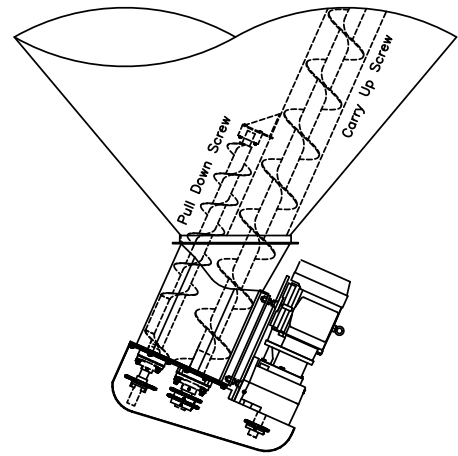

1200 Barrel Round Portable Silo



1200 Barrel Round Portable Silo

- 12'-0" Diameter x 61'-4" Overall Height
- Positive Feed Drive Auger System
- 12" Diameter x 17'-6" Internal Auger
- 20 HP Motor and Gear Box Drive
- Heavy Duty Dual Axle Trailer and Tires
- Air Brakes and Lights Package
- 330 Sq. Ft. Pulse Jet Dust Collector
- Pressure Relief Valve
- Two Speed Trailer Jack Set
- 15'-7" Auger Discharge Height
- Outside Ladder with OSHA Compliant Fall Arrest Cable System
- 4" Fill Pipe with Aluminum Adapter
- 20" Non-Pressurized Inspection Manhole (High Level)
- 20" Non-Pressurized Inspection Manhole (Low Level)
- Solimar Disc Package
- Sandblast, Prime, and Paint
- Standard Colors:
RAL 7038 Gray, RAL 9010 White,
RAL 1001 Tan, RAL 1032 Yellow

Options

- 150 Sq. Ft. Dust Collector
- Bin Level Indicators
- Motor Starter Controls
- Manual Air Valve Controls
- 5" Fill Pipe

Specifications

- Empty Weight 25,300#
- Hitch Weight 10,000#
- 4,800 Cu. Ft. Capacity
- 225 Ton Capacity (Cement)
- Output Capacity Approximately 30 Cu. Ft. Per Minute (12" Screw Conveyor)
- Part Number: BST1200P-RD-AB



1200 Barrel Round Portable Silo

Positive Feed Drive System

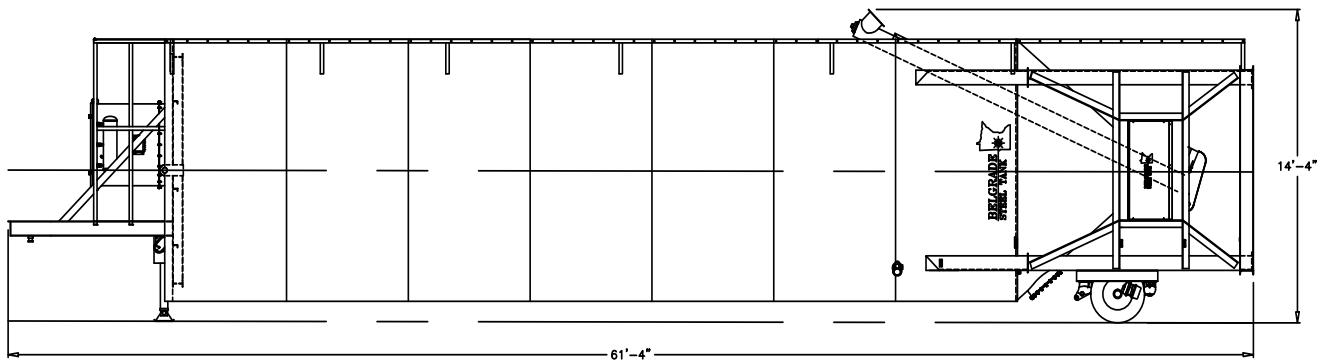
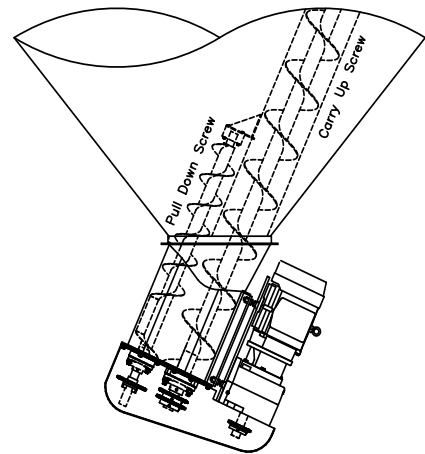
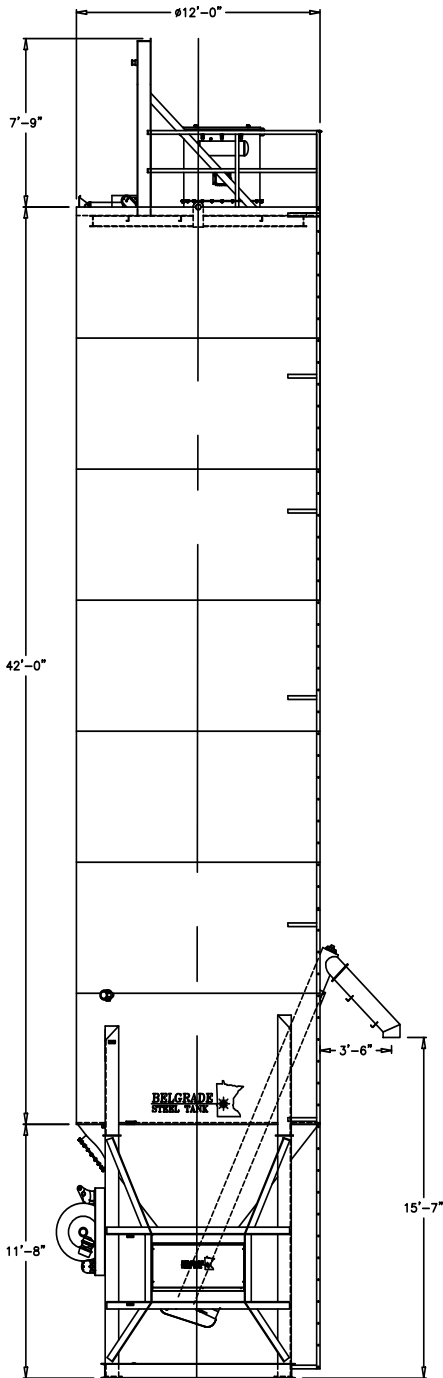

500 Barrel Round Portable Split Silo

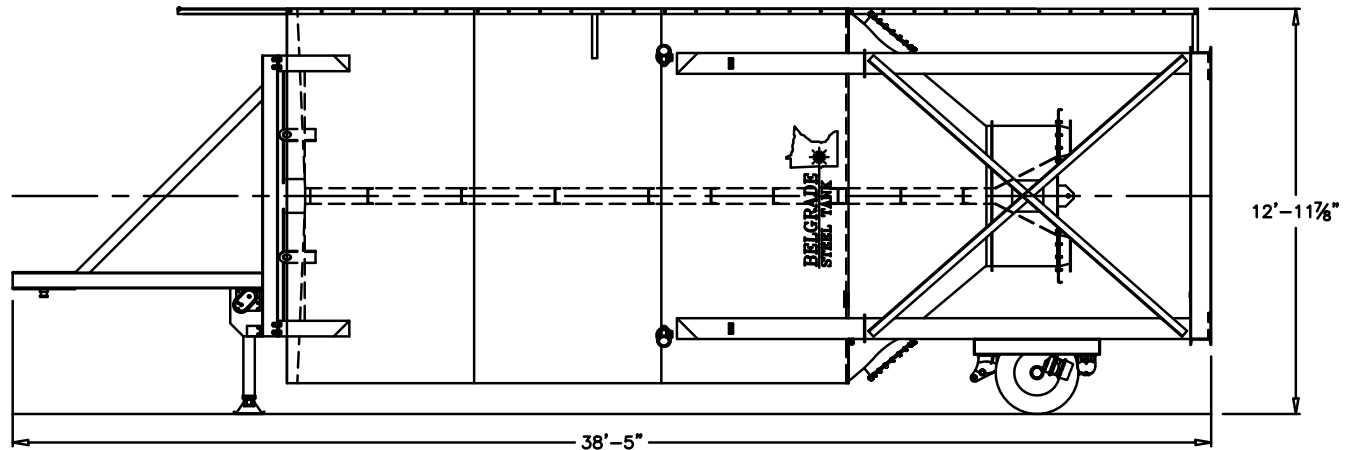

500 Barrel Portable Split Silo

- 12'-0" Diameter x 38'-5" Overall Length
- Heavy Duty Dual Axle Trailer and Tires
- Air Brakes and Lights Package
- (2) 330 Sq. Ft. Pulse Jet Dust Collector
- (2) Pressure Relief Valves
- Two Speed Trailer Jack Set
- 4'-6" Clearance under Discharge
- Outside Ladder with OSHA Compliant Fall Arrest Cable System
- (2) 4" Fill Pipes with Aluminum Adapters
- (2) 20" Non-Pressurized Inspection Manholes (High Level)
- (2) 20" Non-Pressurized Inspection Manholes (Low Level)
- Solimar Disc Package
- Sandblast, Prime, and Paint
- Standard Colors:
RAL 7038 Gray, RAL 9010 White,
RAL 1001 Tan, RAL 1032 Yellow

Options

- 150 Sq. Ft. Dust Collector
- Bin Level Indicators
- Manual Air Valve Controls
- 5" Fill Pipes

Specifications

- Empty Weight: 19,100#
- Hitch Weight: 7,400#
- 2,000 Cu. Ft. Capacity
- 94 Ton Capacity (Cement)
- Part Number: BST500PS-AB

500 Barrel Portable Split Silo

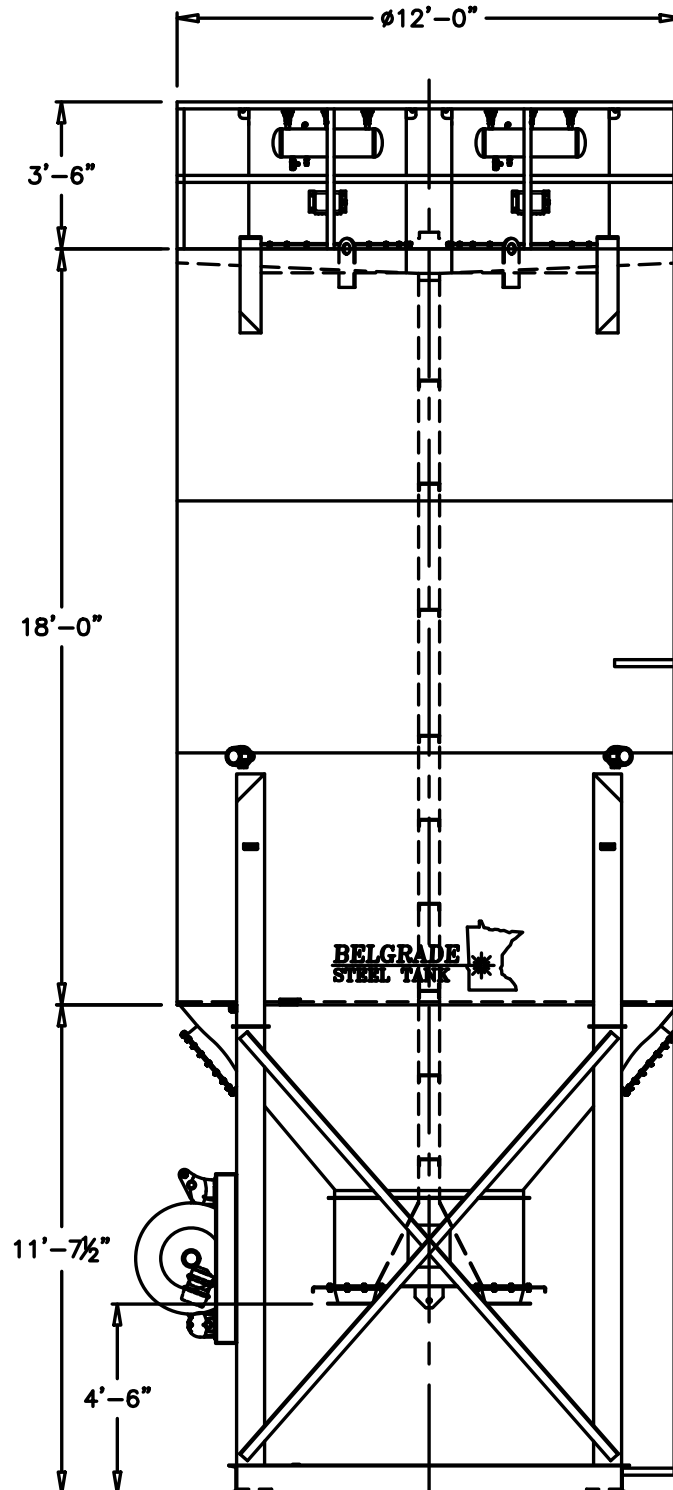

700 Barrel Round Portable Split Silo

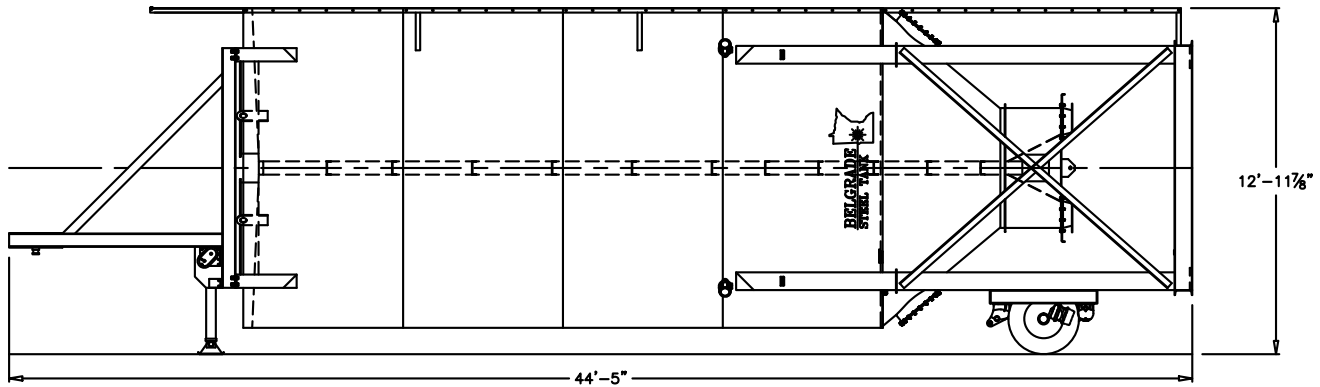

700 Barrel Portable Split Silo

- 12'-0" Diameter x 44'-5" Overall Length
- Heavy Duty Dual Axle Trailer and Tires
- Air Brakes and Lights Package
- (2) 330 Sq. Ft. Pulse Jet Dust Collectors
- (2) Pressure Relief Valves
- Two Speed Trailer Jack Set
- 4'-6" Clearance under Discharge
- Outside Ladder with OSHA Compliant Fall Arrest Cable System
- (2) 4" Fill Pipes with Aluminum Adapters
- (2) 20" Non-Pressurized Inspection Manholes (High Level)
- (2) 20" Non-Pressurized Inspection Manholes (Low Level)
- Solimar Disc Package
- Sandblast, Prime, and Paint
- Standard Colors:
RAL 7038 Gray, RAL 9010 White,
RAL 1001 Tan, RAL 1032 Yellow

Options

- 150 Sq. Ft. Dust Collector
- Bin Level Indicators
- Manual Air Valve Controls
- 5" Fill Pipes

Specifications

- Empty Weight: 24,800#
- Hitch Weight: 9,800#
- 2,600 Cu. Ft. Capacity
- 122 Ton Capacity (Cement)
- Part Number: BST700PS-AB

700 Barrel Portable Split Silo

BELGRADE
STEEL TANK

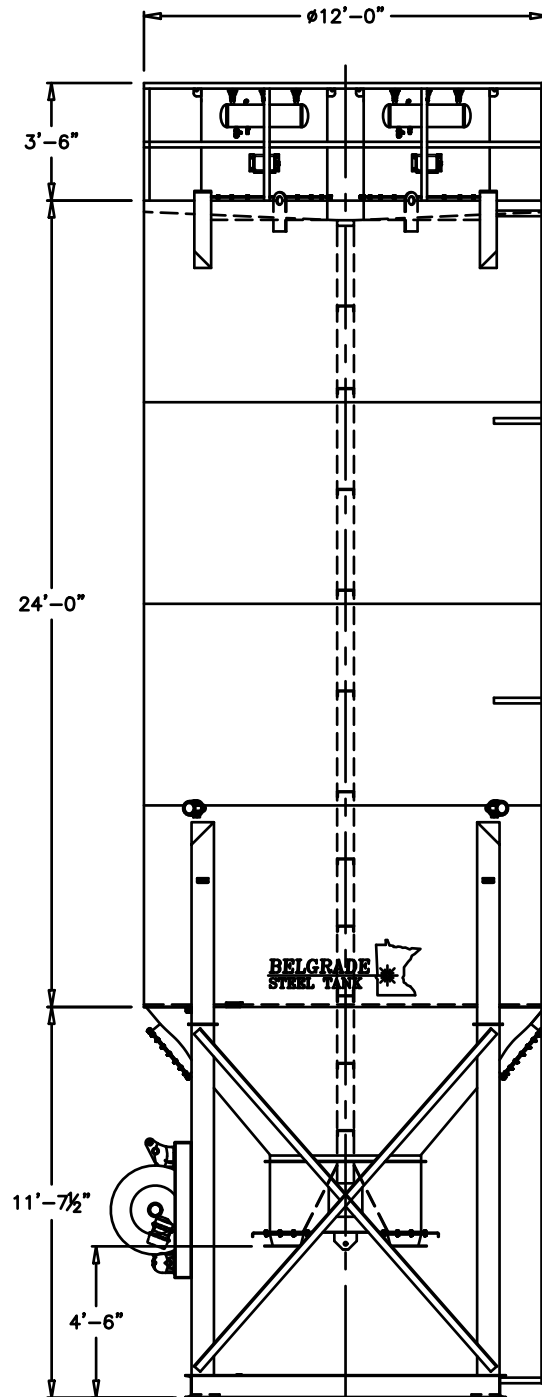

850 Barrel Round Portable Split Silo

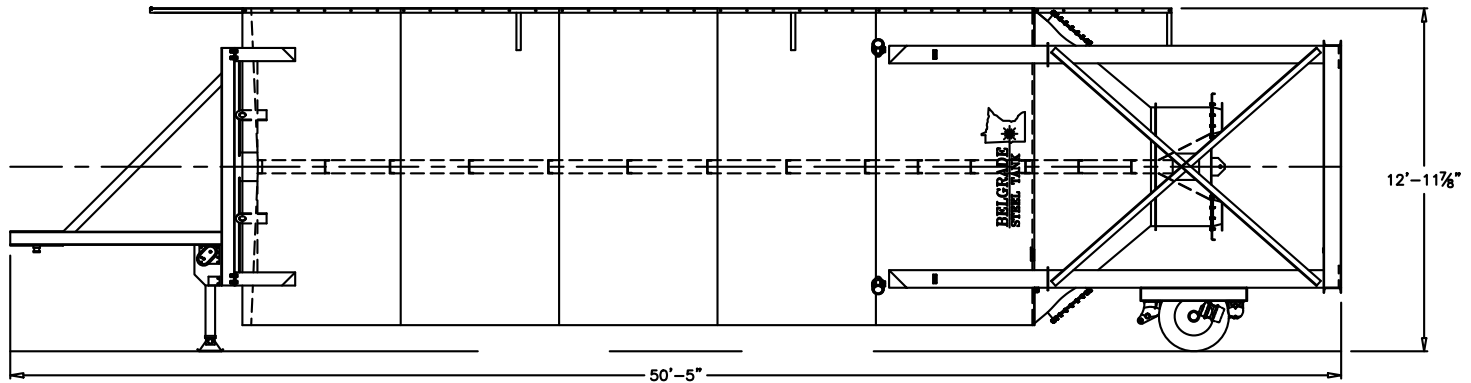

850 Barrel Portable Split Silo

- 12'-0" Diameter x 50'-5" Overall Length
- Heavy Duty Dual Axle Trailer and Tires
- Air Brakes and Lights Package
- (2) 330 Sq. Ft. Pulse Jet Dust Collectors
- (2) Pressure Relief Valves
- Two Speed Trailer Jack Set
- 4'-6" Clearance under Discharge
- Outside Ladder with OSHA Compliant Fall Arrest Cable System
- (2) 4" Fill Pipes with Aluminum Adapters
- (2) 20" Non-Pressurized Inspection Manholes (High Level)
- (2) 20" Non-Pressurized Inspection Manholes (Low Level)
- Solimar Disc Package
- Sandblast, Prime, and Paint
- Standard Colors:
RAL 7038 Gray, RAL 9010 White,
RAL 1001 Tan, RAL 1032 Yellow

Options

- 150 Sq. Ft. Dust Collector
- Bin Level Indicators
- Manual Air Valve Controls
- 5" Fill Pipes

Specifications

- Empty Weight: 27,800#
- Hitch Weight: 11,000#
- 3,400 Cu. Ft. Capacity
- 158 Ton Capacity (Cement)
- Part Number: BST850PS-AB

850 Barrel Portable Split Silo

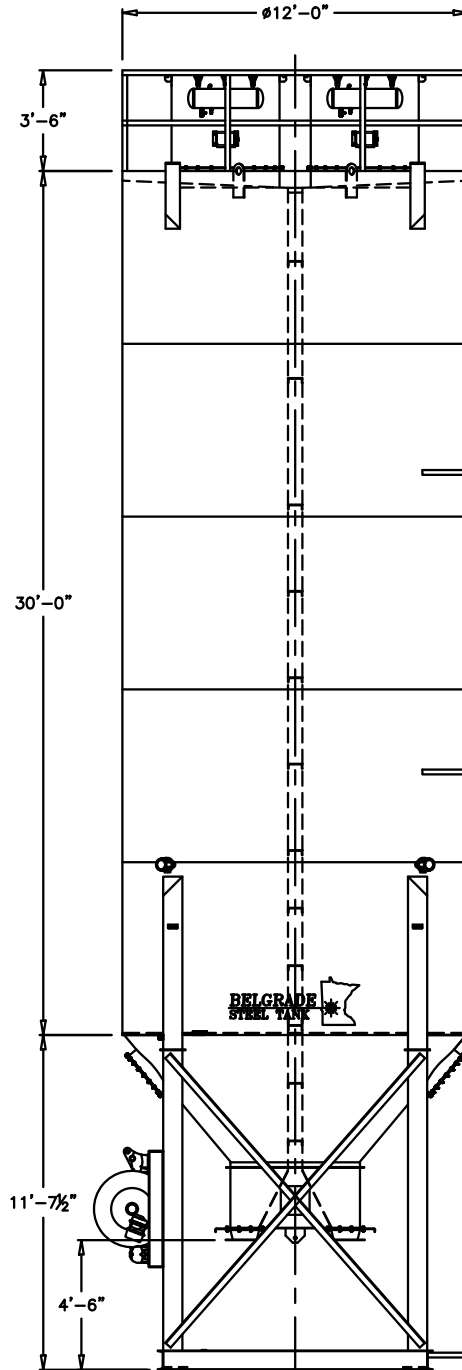

200 Low Profile Portable Silo



200 Barrel Low Profile Portable

- 8'-6" Wide x 29'-5" Overall Length
- 8" Diameter x 17'-0" Auger
- 5 HP Motor and Gear Box Drive
- (1) Heavy Duty Dual Axle with Dual Tires
- Electric Brakes and Lights Package
- 330 Sq. Ft. Pulse Jet Dust Collector
- (4) Screw Jacks
- 8" x 5'0" Auger Extension
- 15'-3" Auger Discharge Height
- 4" Fill Pipe with Aluminum Adapter
- 20" Non-Pressurized Inspection Manhole (High Level)
- 20" Non-Pressurized Inspection Manhole (Low Level)
- Solimar Disc Package
- Sandblast, Prime, and Paint
- Standard Colors:
RAL 7038 Gray, RAL 9010 White,
RAL 1001 Tan, RAL 1032 Yellow

Options

- 150 Sq. Ft. Dust Collector
- Gas Powered Air Compressor
- Bin Level Indicators
- Single Phase Motor
- Hydraulic Drive Motor with Flow Controls and Quick Connect
- 18 HP Gas Motor
- Motor Starter Controls
- Manual Air Valve Controls
- Upgrade to 10" Auger

Specifications

- Empty Weight 8,000#
- Hitch Weight 2,100#
- 800 Cu. Ft. Capacity
- 37 Ton Capacity (Cement)
- Output Capacity Approximately 7 Cu. Ft. Per Minute (7" Screw Conveyor)

BELGRADE
STEEL TANK



200 Low Profile Portable Silo

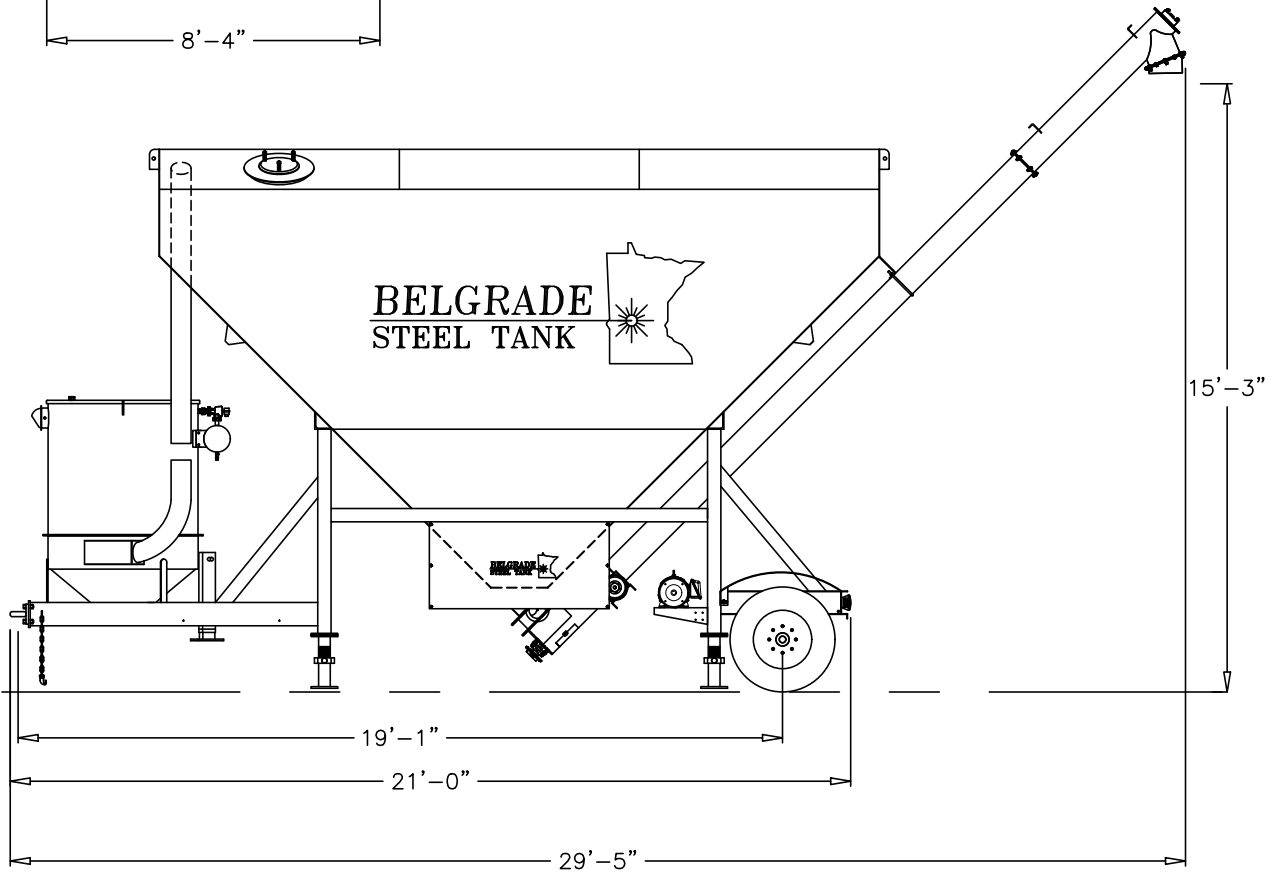
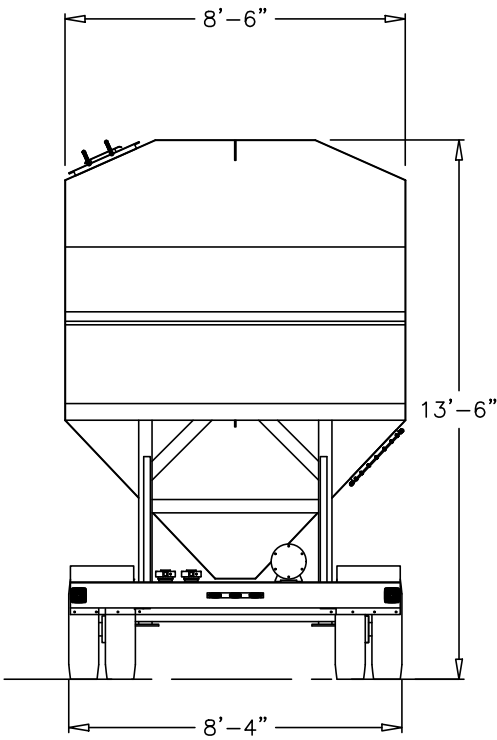

375 Low Profile Portable Silo



375 Barrel Low Profile Portable

- 8'-6" Wide x 38'-2" Overall Length
- 8" Diameter Carry Across and 10" Diameter x 17'-0" Discharge Auger
- 5 HP and 10 HP Motor and Gear Box Drive
- Heavy Duty Axle Trailer and Dual Tires
- 330 Sq. Ft. Pulse Jet Dust Collector
- Pressure Relief Valve
- (4) Screw Jacks
- 15'-7" Auger Discharge Height
- 4" Fill Pipe with Aluminum Adapter
- 20" Non-Pressurized Inspection Manhole (High Level)
- 20" Non-Pressurized Inspection Manhole (Low Level)
- Solimar Disc Package
- Sandblast, Prime, and Paint
- Standard Colors:
RAL 7038 Gray, RAL 9010 White,
RAL 1001 Tan, RAL 1032 Yellow

Options

- 150 Sq. Ft. Dust Collector
- Bin Level Indicators
- Single Phase Motor
- Hydraulic Drive Motor with Flow Controls and Quick Connects
- Motor Starter Controls
- Manual Air Valve Controls
- Air Brakes and Lights Package
- Upgrade to 10" Carry Across and 12" Discharge Auger
- Gas Power Hydraulic Power Unit
- Gas Power Air Compressor

Specifications

- Empty Weight 15,000#
- Hitch Weight 5,600#
- 1,500 Cu. Ft. Capacity
- 70 Ton Capacity (Cement)
- Output Capacity Approximately 15 Cu. Ft. Per Minute (9" Screw Conveyor)



375 Low Profile Portable Silo

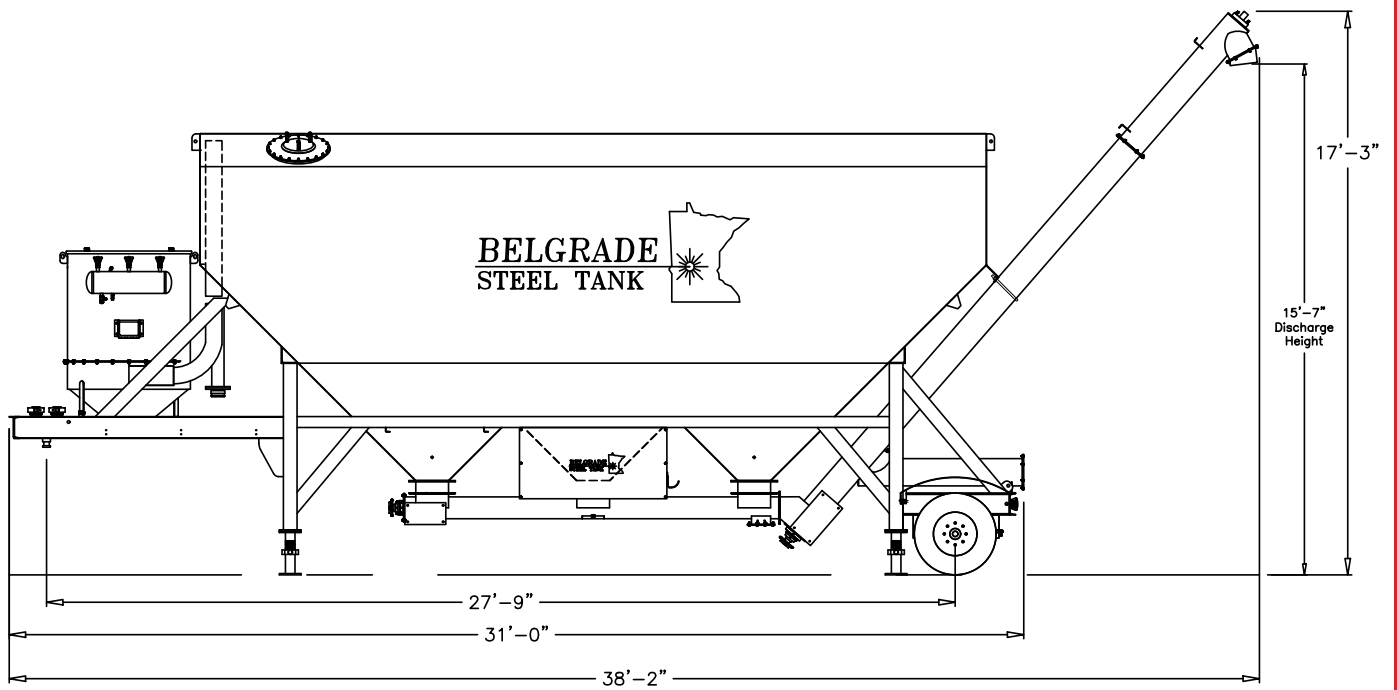
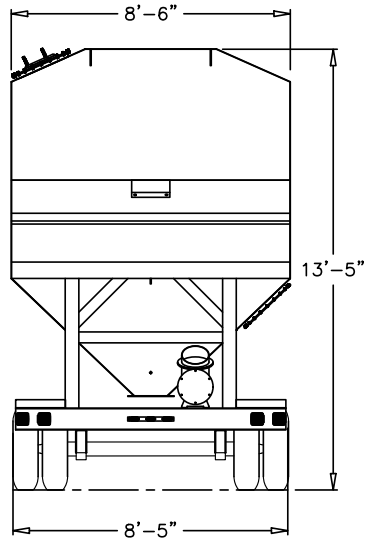

Belgrade Batching Silos

BELGRADE
STEEL TANK



Belgrade Batching Silo

- Structural Stand with all Standard Equipment- 20' Tall Structure with Extension Fill Pipe and Ladder with Fall Arrest Cable System
- Work Platform
- 12 Yard Cement Batching Package with all Standard Equipment

Options

- Bin Level Indicators



12 Yard Cement Scale Hopper

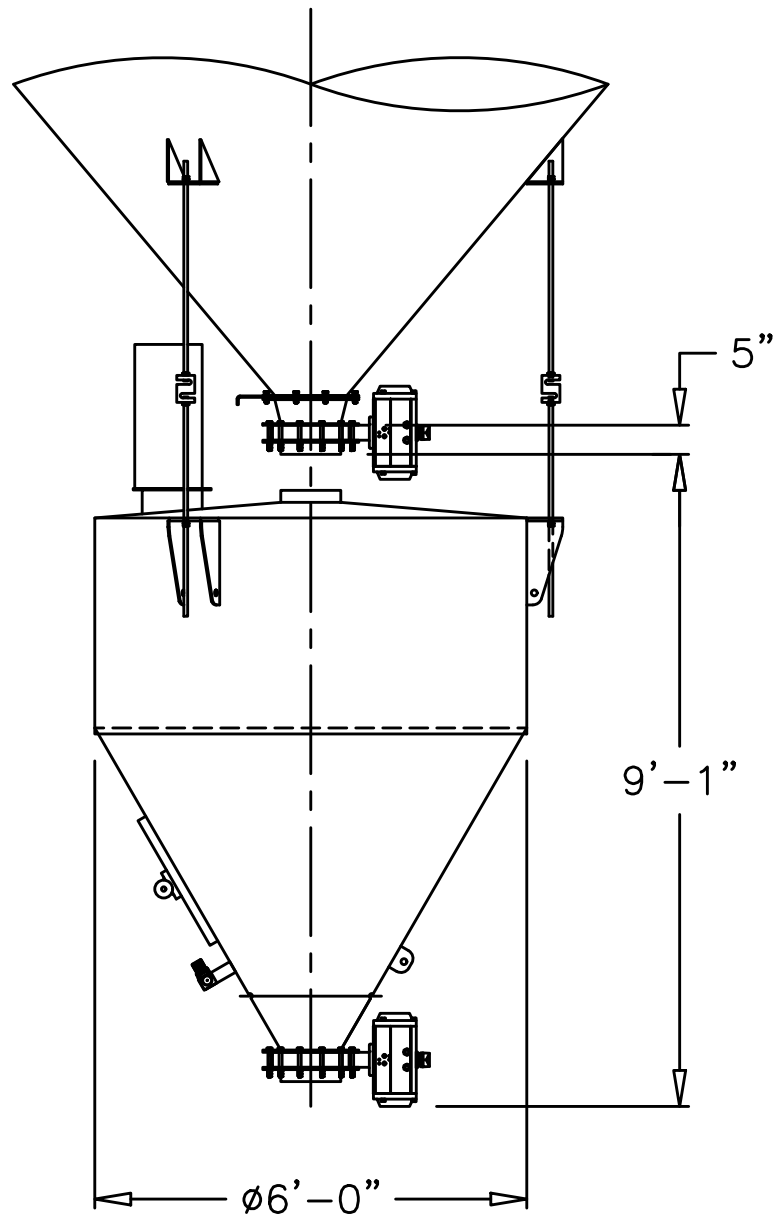

Batching Package

- Scale Hopper with Air Vibrator
- Weigh System with Digital Indicator
- (2) 10" Butterfly Valves with Air Actuators
- Limit Switch
- 16 Sq. Ft. Filter Vent
- (2) Mini Solimar Disc Package
- Regulator & Check Valve
- Gum Rubber and Vinyl Boot

12 Yard Aggregate Scale Hopper



Scale Hopper

- 1/4" & 3/16" Material
- 12" x 38" Gate with 3 1/2" x 8" Air Cylinder
- Air Vibrator
- (4) 15,000# Load Cells and Digital Indicator
- Scale Support Stand

30" x 38'-6" Belt Conveyor

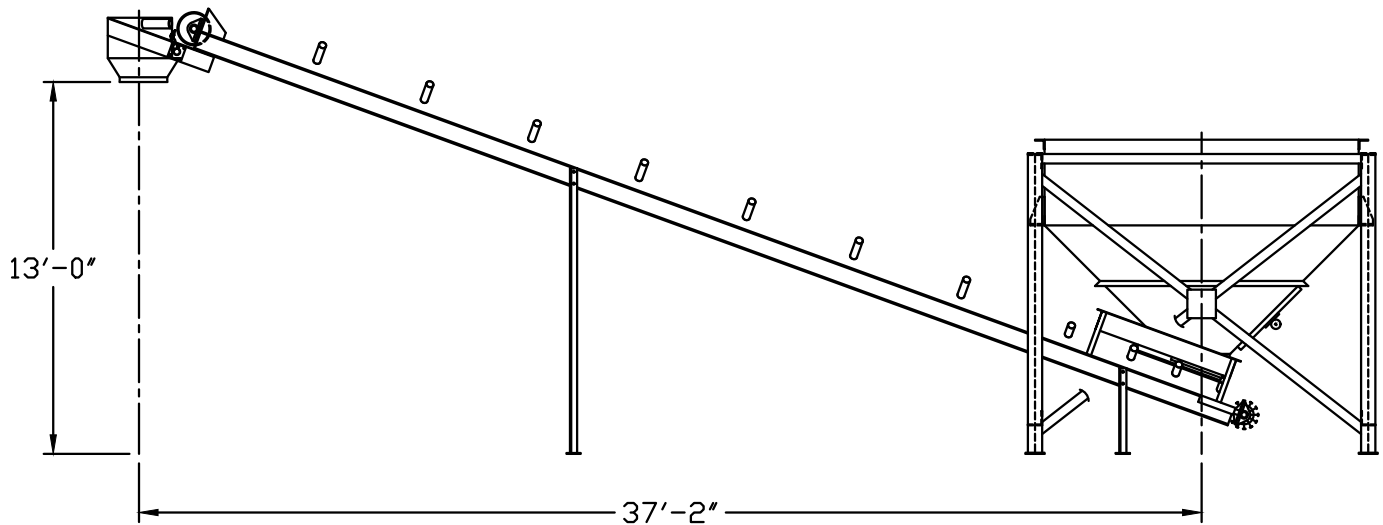

30" x 38'-6" Belt Conveyor

- 300 FPM / 576 TPH
- 8" Channel Frame 20-degree and 35-degree Trough Idlers and Returns
- 30" Wide 3/16 x 1/16 2-ply belt
- 14" Head Pulley with Herring-bone Lagging on 2 - 7/16" Drive Shaft and Pillow Block Bearings
- Individual Belt Tighteners with 3/4" Sealed in Grease Threaded Rods
- 10 HP 3-Phase Motor T.E.F.C.
- Shaft Mount Direct Drive Gear Box with Backstop
- Discharge Hopper with Rubberized Sock
- Torsion Style Belt Wiper
- Water Pipe
- Intermediate Support Stand
- Sandblast, Prime, and Paint
- Standard Colors: RAL 7038 Gray, RAL 9010 White, RAL 1001 Tan, RAL 1032 Yellow

Options

- Water Meter
- Motor Starter Package

12 Yard Decumulative Aggregate Scale Hopper



Scale Hopper

- Two Compartment 12 Yard Scale Hopper
- Weigh System with Digital Indicator and Decumulative Batching Software
- Structural Support Stand
- 30" x 38'-6" Long Belt Conveyor
- 10 HP 3PH Motor and Shaft Mount Direct Drive Gear Reducer with Backstop
- (2) Discharge Gates with Cylinders and Limit Switches
- (2) Air Vibrators with Air Hose
- Collecting Hopper with Gum Rubber Boot
- Torsion Style Belt Wiper
- Water Pipe

Three Compartment Aggregate Bins

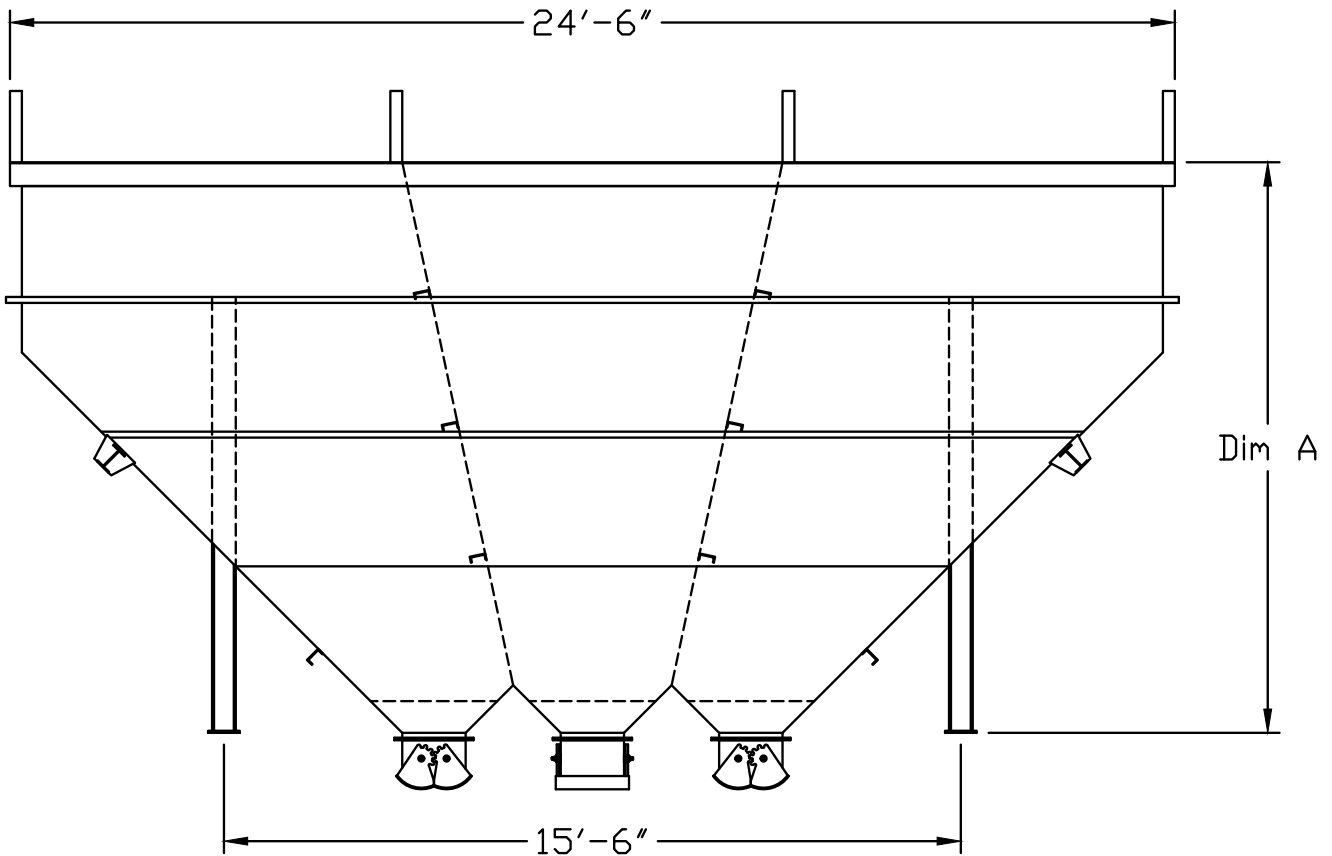

Standard Equipment

- 1/4" Thick Material on all Cones and Sloped Walls
- 3/16" Thick Material on all Straight Walls and Dividers
- Removable Heap Plates: 1'-6" High x 3/16" Thick Material
- (2) 16" x 16" Aggregate Gates with Air Cylinders
- (2) 16" x 48" Aggregate Gates with Air Cylinders
- 8" Beam Structural Stand to Provide 14'-0" Clearance Under Gates
- Optional AR Steel Liner

Capacity In Tons	Bin Height (Excluding Heap Plates)	Weight (Without Stand)	Weight (With Stand)	Dimension A
65	23'-0"	10,360#	15,900#	8'-0"
90	24'-6"	11,360#	16,900#	9'-6"
120	26'-6"	11,980#	17,500#	11'-6"
145	28'-6"	14,340#	20,200#	13'-6"
170	30'-6"	16,180#	22,100#	15'-6"
200	32'-6"	17,850#	23,800#	17'-6"

Three Compartment Aggregate Bins

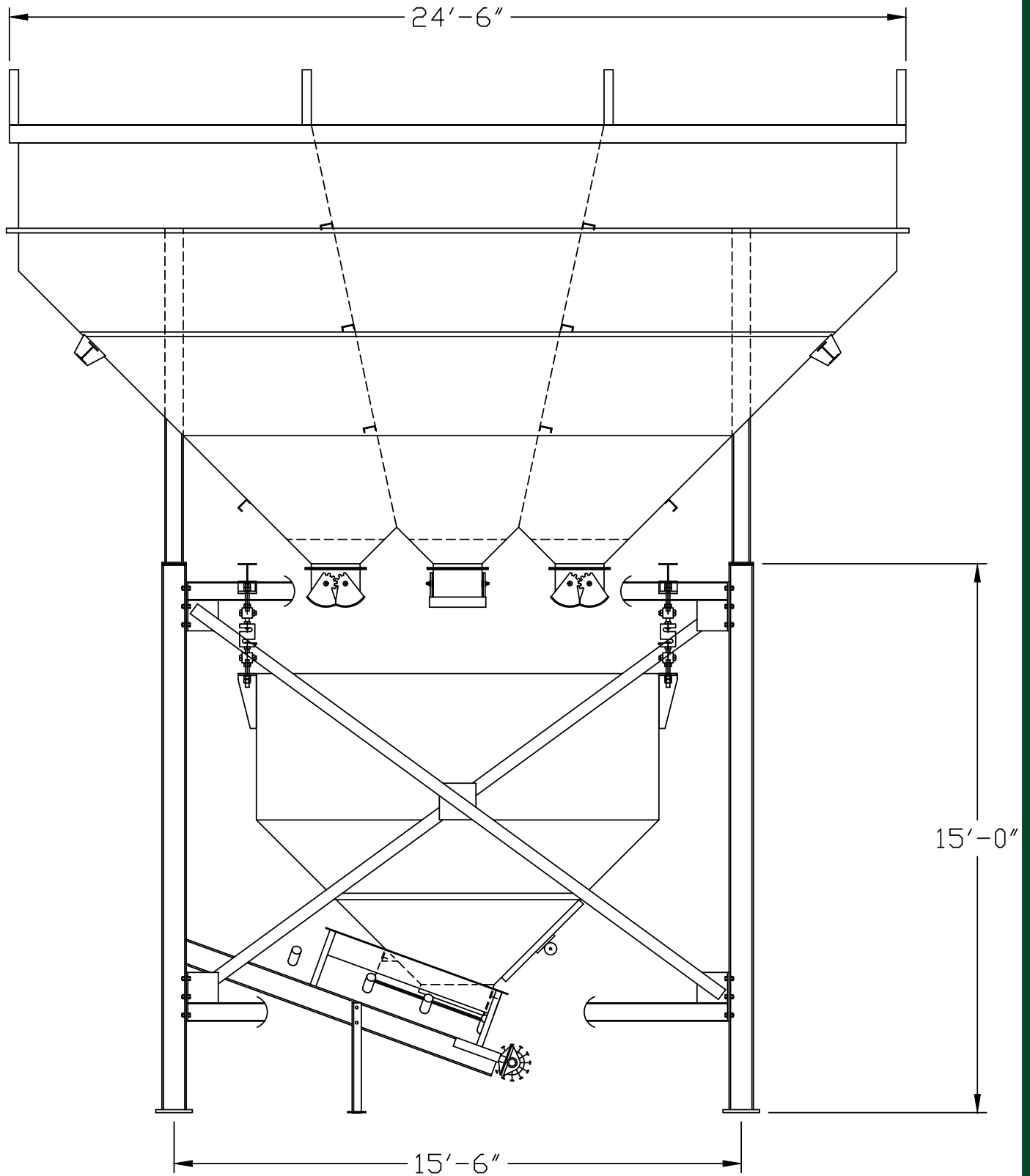

Four Compartment Aggregate Bins

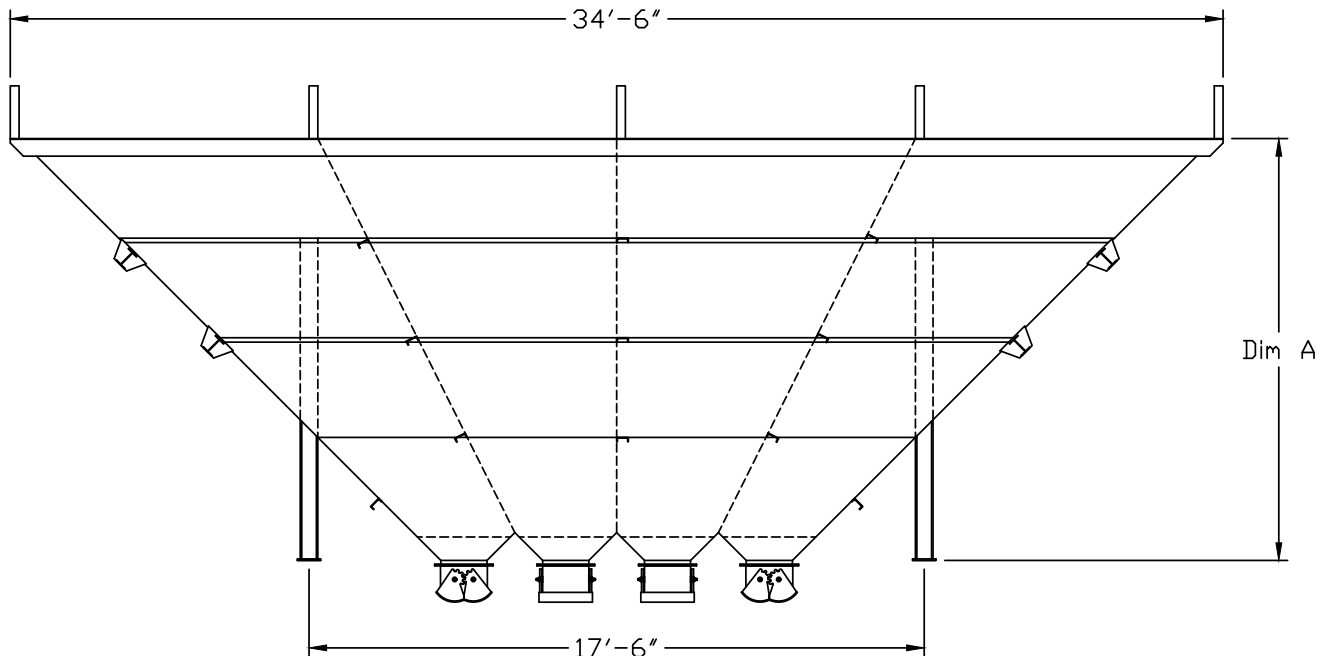

Standard Equipment

- 1/4" Thick Material on all Cones and Sloped Walls
- 3/16" Thick Material on all Straight Walls and Dividers
- Removable Heap Plates: 1'-6" High x 3/16" Thick Material
- (4) 16" x 16" Aggregate Gates with Air Cylinders
- (2) 16" x 48" Aggregate Gates with Air Cylinders
- 8" Beam Structural Stand to Provide 14'-0" Clearance Under Gates
- Optional AR Steel Liner
- Optional Window Pane Design

Capacity In Tons	Bin Height (Excluding Heap Plates)	Weight (Without Stand)	Weight (With Stand)	Dimension A
140	26'-6"	16,515#	22,700#	11'-6"
180	29'-0"	19,915#	26,100#	14'-0"
215	31'-0"	22,100#	28,300#	16'-0"

Four Compartment Aggregate Bins

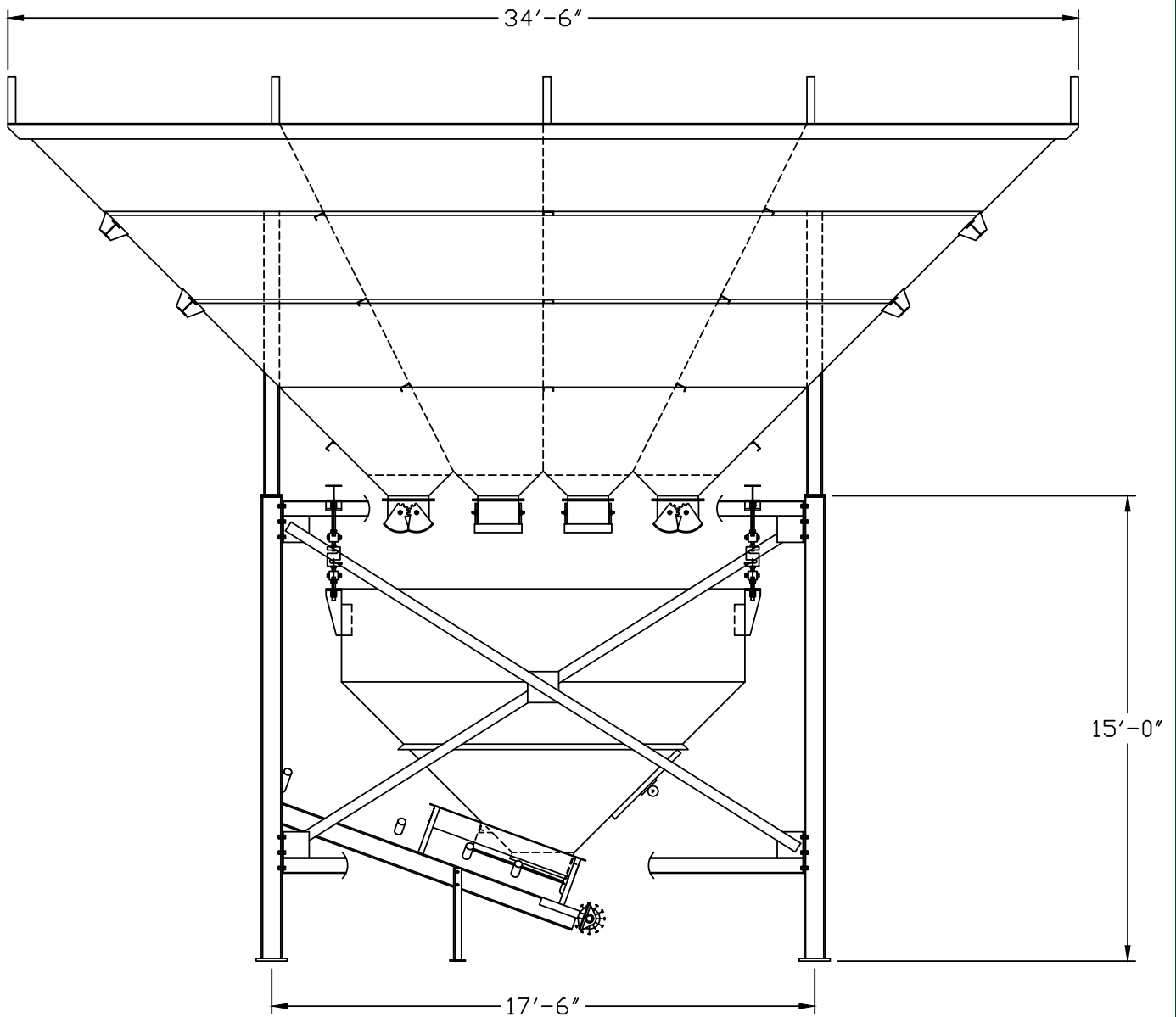

Vertical Flat Bottom Liquid Tanks

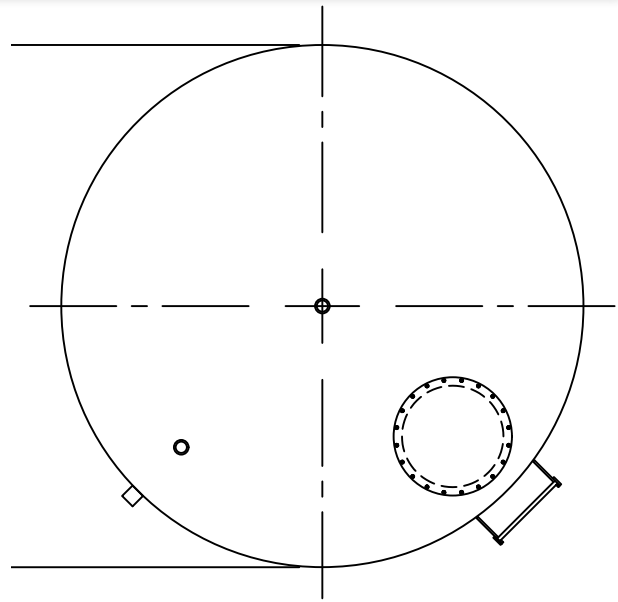
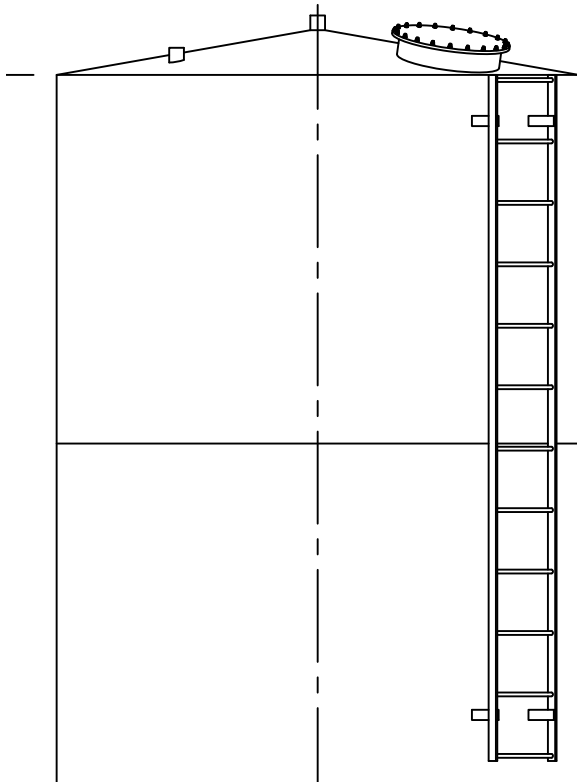

Gallon	A	B
5,000	8'-6"	12'
7,600	8'-6"	18'
10,100	8'-6"	24'
15,200	12'-0"	18'
20,300	12'-0"	24'
25,300	12'-0"	30'
30,400	12'-0"	36'
35,500	12'-0"	42'

Vertical Flat Bottom Liquid Tanks

- A-36 Carbon Steel Construction
- Double-welded Design
- Pitched Roof (Approx. 10 Degrees)
- 20" Non-pressurized Manhole
- 2" NPT Inlet, Outlet, & Vent Couplings
- Outside Ladder with OSHA Compliant Fall Arrest Cable System
- Sandblast, Prime, and Paint
- Standard Colors:
- RAL 7038 Gray, RAL 9010 White, RAL 1001 Tan, RAL 1032 Yellow

Vertical Cone Bottom Liquid Tanks

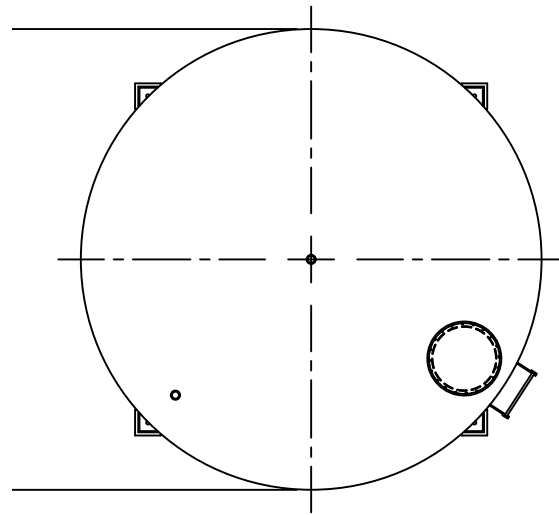
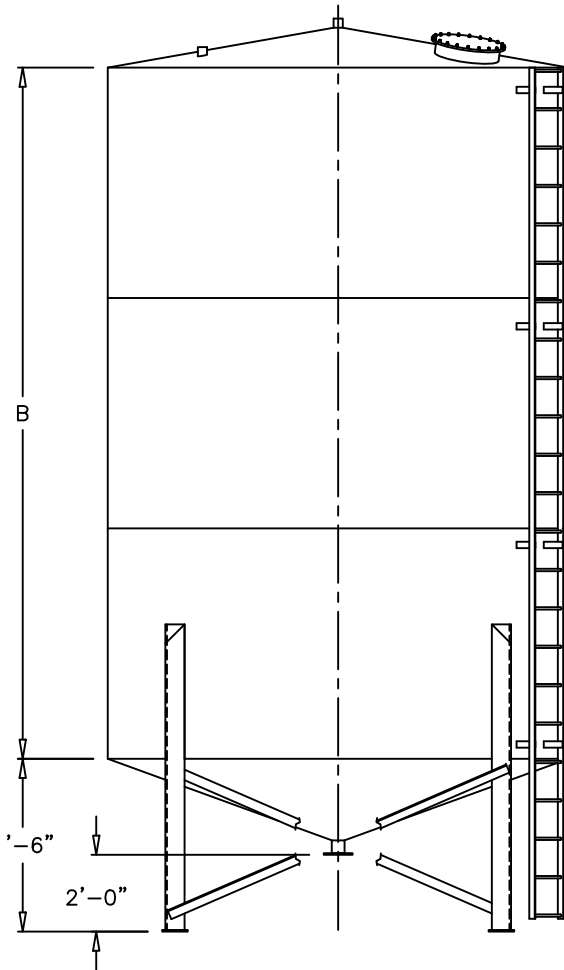

Gallon	A	B
5,000	8'-6"	12'
7,600	8'-6"	18'
10,100	8'-6"	24'
15,200	12'-0"	18'
20,300	12'-0"	24'
25,300	12'-0"	30'
30,400	12'-0"	36'
35,500	12'-0"	42'

Vertical Cone Bottom Liquid Tanks

- A-36 Carbon Steel Construction
- Double-welded Design
- Pitched Roof (Approx. 10 Degrees)
- Sloped Cone (Approx. 20 Degrees)
- 2'-0" Cone Discharge Height
- Angle Iron Legs & X-Bracing
- 20" Non-pressurized Manhole
- 2" NPT Inlet, Outlet, & Vent Couplings
- Outside Ladder with OSHA Compliant Fall Arrest Cable System
- Sandblast, Prime, and Paint
- Standard Colors:
- RAL 7038 Gray, RAL 9010 White, RAL 1001 Tan, RAL 1032 Yellow

Batching and Equipment Controls

Table of Contents

Nine Function Mac Valve Solenoid Panel	59
Six Function Mac Valve Solenoid.....	59
Push Button Control Panel	60
Electric Motor Starter Packages	61
Variable Frequency Drive Packages	62
Badger Electromagnetic Flow Meter	63
Castair 10 HP Air Compressor.....	64
Anti-Overfill Pinch Valve.....	65

Batching and Equipment Controls

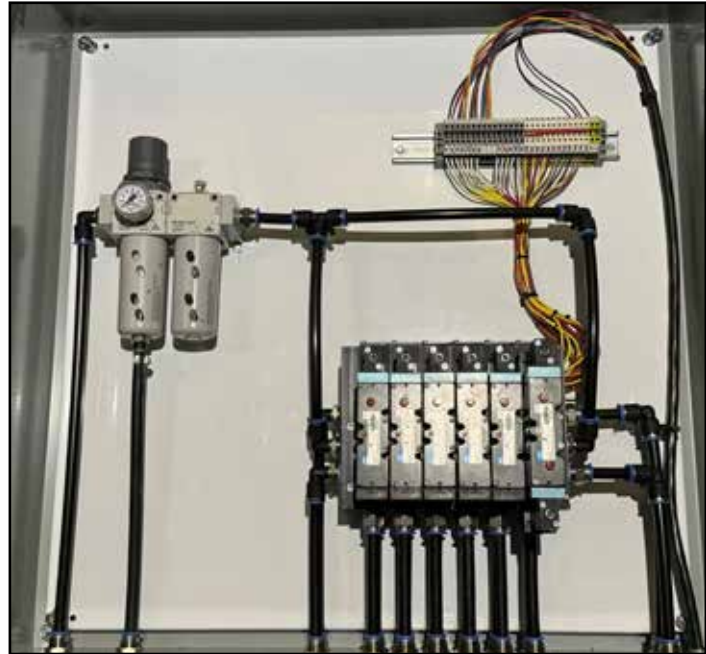

Nine Function Mac Valve Solenoid Panel For Cement Controls - 9-MACSP-ASM

- Four Single Solenoid 9300 Series Valves
- One Double Solenoid 9300 Inching Type Valve
- Four Plant Air Outputs
- Wired To Terminal Strip
- Filter / Regulator
- One Flow Control Valve For Scale Discharge Gate
- Completely Plumbed With Push Lock Fittings
- Mounted And Enclosed In A NEMA 3 Enclosure
- 80'-0" Of 37 Pin Cable
- Hose And Fittings To Plumb Plant

Six Function Mac Valve Solenoid Panel For Aggregate Controls - 6-MACSP-ASM

- Five Single Solenoid 9300 Series Valves
- One Double Solenoid 9300 Inching Type Valve
- Wired To Terminal Strip
- Filter / Regulator / Oiler
- One Flow Control Valve For Scale Discharge Gate
- Completely Plumbed With Push Lock Fittings
- Mounted And Enclosed In A NEMA 3 Enclosure
- 50'-0" Of 37 Pin Cable
- Hose And Fittings To Plumb Plant

Batching and Equipment Controls



Push Button Control Panel - PBCP-ASM

- Two Cement Feed Momentary Buttons
- Two Cement Aeration Maintained Buttons
- One Cement Scale Open Button
- One Cement Scale Closed Button
- One Cement Scale Open Indicator
- One Cement Scale Vibrator Maintained Button
- One Cement Scale Aeration Maintained Button
- Four Bin Indicator Lights
- Two Dust Collector Vibrator Switches
- Four Aggregate Feed Momentary Buttons
- One Aggregate Scale Open Button
- One Aggregate Scale Closed Button
- One Aggregate Scale Open Indicator
- One Aggregate Scale Vibrator Maintained Button
- One Transfer Belt On/ Off Switch
- One Power On/ Off Switch
- One Power Indicator Light
- One Main Circuit Breaker
- One Badger PC-200 Water Meter Controller

Batching and Equipment Controls



Electric Motor Starter Packages - EMSP-ASM

- NEMA 3 Enclosure
- Main Disconnect
- Control Transformer
- Fuses
- Start/ Stop Buttons (local or remote mounting)
- 208V/ 240V/ 480V
- Single or Three Phase

Batching and Equipment Controls



Variable Frequency Drive Packages - VFD-ASM

- NEMA 3 Enclosure
- Main Disconnect
- Constant Torque Drive
- Fuses
- Field Adjustable Speed Control (analog or potentiometer)
- 208V / 230V / 460V
- Single or Three Phase

Batching and Equipment Controls



Badger Electromagnetic Flow Meter 3-BWMM-ASM

- 3" Diameter Magnetic Pulse Meter
- Scalable Electronics
- Non-Obstructive Flow Through Pipe Design
- Butterfly Valve, Actuator, Solenoid, and Filter with Regulator

Batching and Equipment Controls



Castair 10 HP Air Compressor - 10HP-AC-ASM

- 10 HP 3 PH Air Compressor
- Horizontal 120 Gallon Capacity Tank
- Refrigerated Air Dryer
- Filter with Auto Drain
- Start Up Kit
- Magnetic Starter

Batching and Equipment Controls



Anti-Overfill Pinch Valve - 4-PV-ASM / UPGRADE 5-PV-ASM

- 4" Cast Aluminum Pinch Valve
- Control Panel with Audible and Visual Warning Devices
- Regulator and Solenoid

Upgrade Available:

- 5" Cast Aluminum Pinch Valve
- Control Panel with Audible and Visual Warning Devices
- Regulator and Solenoid

(Must be used with a high level indicator.)

330 Sq.Ft. Pulse Jet Dust Collector



Operation Recommendations: Supply unit with 100 PSI air pressure and 110 volt power. Turn on unit when the filling cycle begins and continue to operate unit 15 minutes after filling cycle is complete.

Dust Collector Specifications

Total Filtration Area	330 Sq. Ft.
Air to Cloth Ratio (ACFM/Sq.')	4.8
Pressure Drop	6"
Air Capacity	1600
Outlet Area (Sq.')	.83
Cleaning Method	Pulse Jet
Inlet Dust Concentration at 15 Gr./Cu'	25,000
Outlet Emissions (Gr./Min)	2.50
Outlet Dust Loading (Gr./Cu.')	.0015
Air Consumption	8 CFM
Solenoids	3 w/ Timer Board

Filter Cartridge Specifications

Dimensions	(6) 10.09" OD x 5.75" ID x 30" height
Top End Cap	G60 Galvanized-Open with 11.000" Flange
Bottom End Cap	G60 Galvanized-Closed
Gasket	5/8" Height x 10" ID Neoprene
Outline Retainer	Retainer Bands
Inner Core	Galvanized Expanded Metal, 72% Open
Filter Area	55 Square Feet
Fiber	100% Spun Bond Polyester
Material Weight	8 oz / Square Yard
Permeability	24 C.F.M.
Mullen Burst Dry	388 PSI
Temperature Limit	275 Degrees Fahrenheit
Efficiency	99.99%

330 Pulse Jet Dust Collector

Instructions for Changing Filter Cartridges

1. Remove the round cover on top of the dust collector.
2. Loosen hold-down knobs for blower pipes.
3. Loosen the (3) pipe unions and remove the blower pipes.
4. Remove the filter cartridge holders.
5. Remove the used filter cartridges.
6. Install new filter cartridges and re-install the filter cartridge holders (make sure the cartridge is centered in the hole) tighten the nuts on the filter cartridge holders (do not overtighten).
7. Re-install blower pipes and tighten the pipe unions (making sure the blower pipe nozzles are centered in the filter cartridge)
8. Tighten the hold-down knobs for the blower pipes.
9. Replace the round cover and secure with hold-down knobs.
10. Inspect the filter cartridge monthly and replace every 6 to 12 months.

"Belle" Style Dust Collector



Dust Collector Specifications

The dust collector is equipped with either an air powered or electric powered vibrator used for cleaning of the bags. If air powered, connect air supply line to the 3/8" NPT coupling located on center above the door, and supply the vibrator with 80 psi oiled or non-oiled air. If electric powered, reconnect power cord which exits the top side of dust collector, to the control box supplied. Operate vibrator for 15 minutes after each load of material has been blown in.

Sq. Ft. Bag Area	Cap. Cement
150	375 C.F.M.

Filter Sock Specifications

Style	PE 37
Fiber	100% Polyester
Weight	9 oz./Sq. Yd.
Construction	Spun/ Spun
Count	100W x 60F
Air Permeability	20-30 C.F.M.
Mullen Burst	500 PSI
Tensile Strength	Warp Direction 300# Fil Direction 275#
Max. Operating Temperature	275 Degrees F`
Efficiency	99.99%

“Belle” Style Dust Collector

Instructions for Changing Dust Filter Socks

1. Remove the round top lid and rectangular access door of the dust collector.
2. Loosen the (4) 3/8” adjustment bolts above the round vibrator plate (This allows slack in the socks).
3. Loosen the hose clamps at the bottom of the dust sock.
4. Pull the dust socks up off the sock rings and unhook them from the J-Bolts.
5. Hook the new dust sock on the J-Bolt.
6. Place the bottom of the dust sock over the sock ring making sure the dust sock is all the way to the bottom of the sock ring.
7. Place the hose clamp around the sock ring and tighten.
8. Once all the socks have been replaced, tighten the (4) 3/8” adjustment bolts until the dust socks are taut or free of wrinkles.
9. Check to make sure that none of the dust socks have pulled off the sock rings.
10. Replace the round top lid and the rectangular access door.
11. Inspect the dust socks monthly and replace every 6 to 12 months.

Belgrade Auger Worksheet

- A. _____
- B. _____
- C. _____
- D. _____
- E. _____
- F. _____

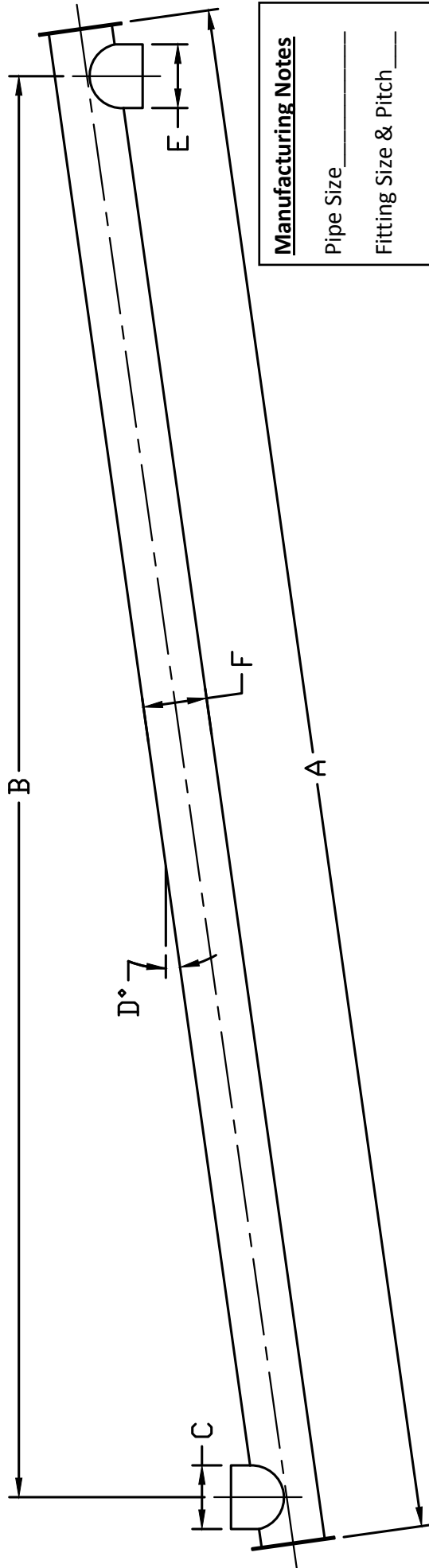

Ship to: _____ Motor: _____ H.P. _____ -Phase _____
 _____ Gear Box _____
 _____ Drive from: Inlet or Discharge End
 Phone: _____ Hanger Bearing: None One Two
 _____ Paint Color _____
 _____ Approval Signature _____

Manufacturing Notes	
Pipe Size	_____
Fitting Size & Pitch	_____
Shaft Size (s)	_____
Pulley Size	_____
Sprocket Size	_____
Belt Size	_____
Chain Length	_____

All Full Pitch

Job: _____

Drive Shaft: _____

For: _____

Tail Shaft: _____

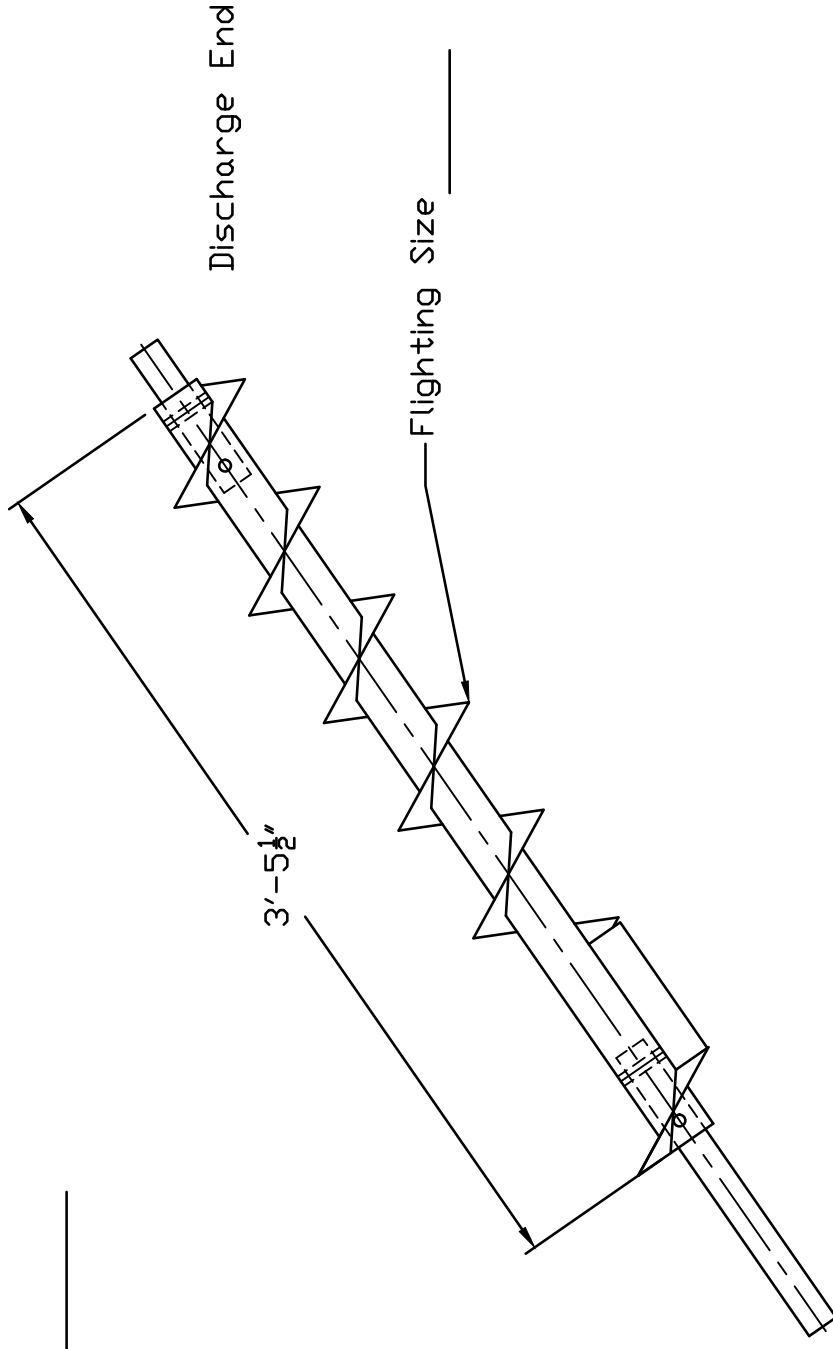

	TITLE: Replacement Pull Down Screw Worksheet	
	DRAWING NUMBER:	DATE:
	SCALE: NTS	DRAWN BY: NAT
		REVISED:
	PO#	APPROVED BY:
	DATE CHECKED:	
	FOR:	
	JOB:	

THIS DRAWING IS THE PROPERTY OF BELGRADE STEEL TANK, INC. IT SHALL NOT BE USED OR REPRODUCED EITHER WHOLLY OR IN PART EXCEPT WITH WRITTEN AUTHORIZATION. ALL RIGHTS RESERVED.

2/3 & Full Pitch

Job: _____

Drive Shaft: _____
For: _____

Tail Shaft: _____

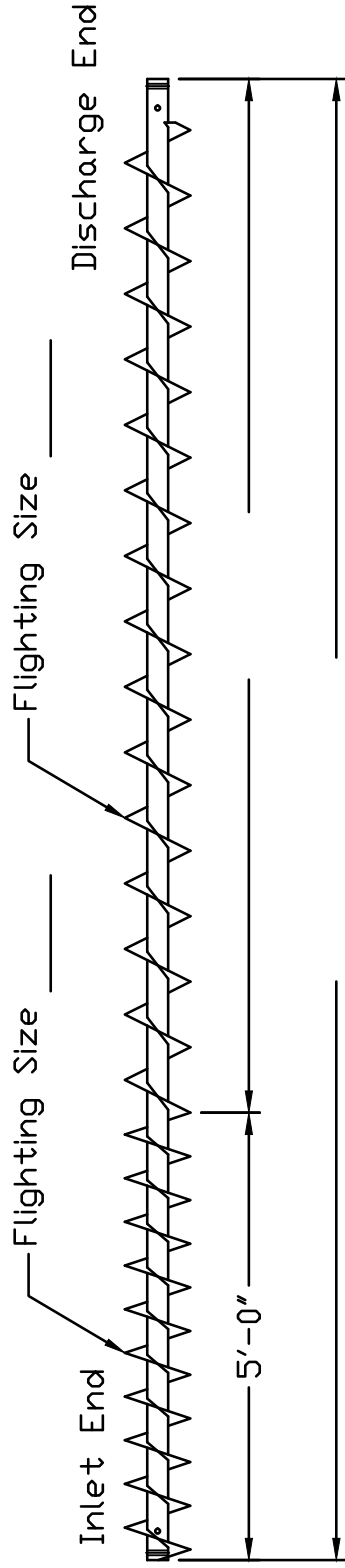

 BELGRADE STEEL TANK		TITLE: Replacement Screw Worksheet	
DRAWING NUMBER:	DATE:	DRAWN BY: NAT	REVISED:
SCALE: NTS	PO#	DATE CHECKED:	APPROVED BY:
THIS DRAWING IS THE PROPERTY OF BELGRADE STEEL TANK, INC. IT SHALL NOT BE USED OR REPRODUCED EITHER WHOLLY OR IN PART EXCEPT WITH WRITTEN AUTHORIZATION. ALL RIGHTS RESERVED.		FOR:	JOB:

All Full Pitch

Job: _____

Drive Shaft: _____

For: _____

Tail Shaft: _____

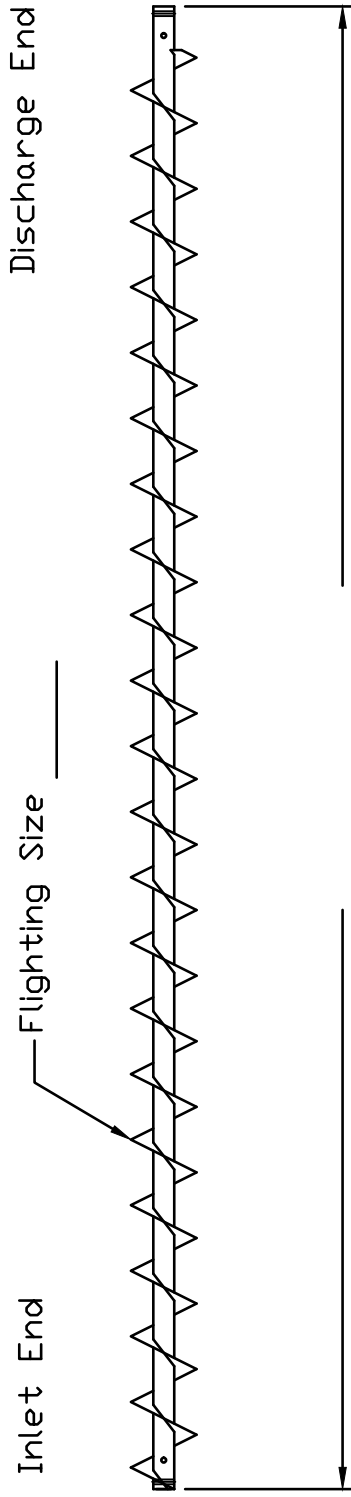

THIS DRAWING IS THE PROPERTY OF BELGRADE STEEL TANK, INC. IT SHALL NOT BE USED OR REPRODUCED EITHER WHOLLY OR IN PART EXCEPT WITH WRITTEN AUTHORIZATION. ALL RIGHTS RESERVED.

TITLE: Replacement Screw Worksheet	
DRAWING NUMBER:	DATE:
SCALE: NTS	DRAWN BY: NAT
PC#	REVISED:
DATE CHECKED:	APPROVED BY:
FOR:	
JOB:	

Parts and Accessories

Aggregate Gates P/N

12" x 38" with 3 1/2" x 8" Air Cylinder	12-AGGATE-38
16" x 16" with 4" x 10" Air Cylinder	16-AGGATE-16
16" x 24" with 4" x 10" Air Cylinder	16-AGGATE-24
16" x 48" with 4" x 10" Air Cylinder	16-AGGATE-48
Easton Agg Gate Limit Switch with Arm	AGG-LIMSWT
Agg Gate Bushing Kit (4 Bolts, Bushings, Nuts, & Washers)	AGGTE-BUSHKT

Air Cylinders P/N

3 1/2" x 8" Air Cylinder	35-AIRCYL-8
4" x 10" Air Cylinder	4-AIRCYL-10
4" x 10" Air Cylinder Repair Kit	410-AIRCYL-REPKT
3 1/2" x 8" Air Cylinder Repair Kit	358-AIRCYL-REPKT

Air Line Fittings P/N

Straight Fittings...	
...(Specify Thread i.e. 1/8" + Air Line Outside Diameter)	18NPT-12PLSF
90 Degree Elbow Fittings...	
...(Specify Thread i.e. 1/8" + Air Line Outside Diameter)	18NPT-12PLEF

Air Line P/N

3/8" OD x 1/4" ID (per foot) Air Line	3814-AIRLNE
1/2" OD x 3/8" ID (per foot) Air Line	1238-AIRLNE

Air Pad P/N

Air Pad (Internal)	AIRPD-INT
Air Pad with Kit (External)	AIRPD-EXT
Air Pad Cone Assembly...	
...(Air Pad, Manifold, Regulator, Polytube, Fittings, & Bracket)	AIRPD-CONE-ASM
Air Pad Hardware Kit	AIRPD-HDKT
Solimar Vibratory Disc	SVD-4300
Solimar Vibratory Disc Cone Assembly	SVD-CONE-ASM
(Air tank w/regulator, pressure relief valve and mounting brackets, (1) solenoid, (4) solimar discs, poly tubing, timer board)	
Solimar Vibratory Disc Solenoid Valve	SVD-SOL-VALVE
Solimar Vibratory Disc Timer Board	SVD-TB

Aluminum Adapter P/N

4" Aluminum Adapter	4-ALMADP
5" Aluminum Adapter	5-ALMADP
4" Dust Cap	4-ALMADP-DC
5" Dust Cap	5-ALMADP-DC
4' TTMA Aluminum Adaptor	4-ALMA-TTMA
4' ANSI Aluminum Adaptor	4-ALMA-ANSI

Parts and Accessories

Bearings (4 Bolt Flange Style) P/N

1 1/4" 4 Bolt Flange Bearing	F4B-SC-207
1 1/2" 4 Bolt Flange Bearing	F4B-SC-208
1 15/16" 4 Bolt Flange Bearing	F4B-SC-210
2" 4 Bolt Flange Bearing	F4B-SC-211

UHMW Bearing P/N

1 1/2" UHMW Bearing	15-UHMWBEARING
2" UHMW Bearing (w/ 2" Locking Collar)	2-UHMWBEARING

Rubber Bearing Gasket P/N

1 1/4" Rubber Bearing Gasket	125-RUBBER-GAS
1 1/2" Rubber Bearing	15-RUBBER-GAS
1 15/16" Rubber Bearing Gasket	19-RUBBER-GAS
2" Rubber Bearing Gasket	2-RUBBER-GAS

Block Bearing P/N

1 1/2" Bore UHMW Block Bearing	15UHMW-BBRG
--------------------------------	-------------

Belt Conveyor Discharge Hopper P/N

30" Belt Conveyor Discharge Hopper (Old Style)	30-BCDH-ASM-O
30" Belt Conveyor Discharge Hopper (New Style)	30-BCDH-ASM-N
30" Torsion Belt Wiper	30-TORBW

Bin Level Indicator P/N

110 Volt Bin Level Indicator	BLI-110V
12 Volt Bin Level Indicator	BLI-12V
110 Volt Bin Level Indicator with Extension Probe (High Level)	BLI-110V-WP
12 Volt Bin Level Indicator with Extension Probe (High Level)	BLI-12V-WP
Light Package for Bin Level Indicator	BLI-110V-LP / BLI-12V-LP
Bin Level Indicator Extension Probe	BLI-EP
Bin Level Indicator Paddle	BLI-PDL
Bin Level Indicator Flex Coupling	BLI-FC
6" Bin Level Indicator Extension w/ Flange & Cover	6BLI-EXT-FC
Audio/Visual Alarm Package	AV-ALARM-PKG

Centrifugal Clutch P/N

Clutch for Gas Engine	1800-S-CENCLT
Clutch Lining Kit	1800-CENCLT-REPKT

Parts and Accessories

Dust Collector Parts

P/N

10" x 30" Dust Filter Cartridge	DC-1030
9" x 30" Dust Filter Cartridge	DC-930
8" Diameter x 2' Long Dust Filter Sock	DS-2
8" Diameter x 4' Long Dust Filter Sock	DS-4
8" Diameter x 6' Long Dust Filter Sock	DS-6
J-Bolt	DH-JBOLT
Dust Filter Sock Clamp	HC-8
Free Standing Base w/ Clean Out	DH-FSB
Dust Collector Shaker Plate	DH-SHKPLT
Dust Collector Flange	DH-MF
Dust Collector Lid	DH-LID
Filter Vent Cone	16-FILVNT-CONE
Filter Vent Flange	16-FILVNT-MF
Pulse Jet Dust Collector Solenoid with Coil	330-PJDH-SOLC
Pulse Jet Dust Collector Timer Board	330-PJDH-TB

Fill Pipe

P/N

4" (per foot) Fill Pipe	4-SCH40-FILL
5" (per foot) Fill Pipe	5-SCH40-FIL
4" Fill Pipe Elbow (90 Degree)	4-SCH40-FILLELBW
5" Fill Pipe Elbow (90 Degree)	5-SCH40-FILLELBW
4" Fill Pipe Flange	4-FILL-FLG
5" Fill Pipe Flange	5-FILL-FLG
4" Offset Elbow w/ (2) Flanges	4OFF-ELBW
5" Offset Elbow w/ (2) Flanges	5OFF-ELBW

Flop Gate

P/N

2 Way Gate w / 3 1/2" x 8" Air Cylinder	2WGATE-358-ASM
3 Way Gate w / 3 1/2" x 8" Air Cylinder	2WGATE-358-ASM

Parts and Accessories

Gear Reducers	P/N
Boston F862B-10S-B9 (Inline Style)	F862B-10S-B9
Boston F872B-10S-B11 (Inline Style)	F872B-10A-B11
Boston RF652A-10-B13 (Inline Style)	RF652A-10-B13
Boston 732-10E-J Right Angle Drive Gear Reducer	732-10E-J
Dodge 5Hp Direct Drive	D5HPDD-A
Dodge 10Hp Direct Drive	D10HPDD-A
Dodge 20Hp Direct Drive	D20HPDD-A
Dodge 30Hp Direct Drive	D30HPDD-A
Dodge 10Hp 18:1 Gear Reducer with Back Stop	D10HPDD-BC
Dodge 20Hp 18:1 Gear Reducer with Back Stop	D20HPDD-BC
Dodge 25Hp 18:1 Gear Reducer with Back Stop	D25HPDD-BC

Grease Pack Assembly	P/N
1 1/4" Grease Pack Assembly	125-GP-ASM
1 1/2" Grease Pack Assembly	15-GP-ASM
1 15/16" Grease Pack Assembly	19-GP-ASM
2" Grease Pack Assembly	2-GP-ASM

Gum Rubber Boot Sock (1/4" Thick)	P/N
10 3/4" x 2' - 0" Long Gum Rubber Boot Sock	1075GRB-2-0
10 3/4" x 4' - 0" Long Gum Rubber Boot Sock	1075GRB-4-0
20 1/2" x 30" Long Gum Rubber Boot Sock	205GRB-20

Jam Gate Assembly	P/N
10" Jam Gate Assembly	JAMGTE-ASM-10
12" Jam Gate Assembly	JAMGTE-ASM-12

Jaw Clutch Assembly	P/N
#60 Jaw Clutch Assembly...	15CLT60-ASM
...(Includes Driven & Sliding Jaw, Yoke & Handle)	
#80 Jaw Clutch Assembly...	15CLT80-ASM
...(Includes Driven & Sliding Jaw, Yoke & Handle)	
Brass Yoke (only)	BRYK-15
Jaw Clutch Handle Assembly	CLT-HND-ASM
#80 Driven Jaw	JC80BS24-15DJ
#60 Driven Jaw	JC60BS24-15DJ
Sliding Jaw	JC-15SJ
Jaw Clutch Air Cylinder	JC-AC

Parts and Accessories

Bray Accessories

P/N

10" Bray Butterfly Valve	BRAY-10BV
12" Bray Butterfly Valve	BRAY-12BV
Bray Actuator	BRAY-QTACT
Bray Actuator Repair Kit	BRAY-QTACT-REPKT
Limit Switch	BRAY-LIMSWT
Manual Handle	BRAY-MANHDL
Single Solenoid with Coil	BRAY-1SOL-COIL
Double Solenoid with Coils	BRAY-2SOL-COIL
10" Mating Flange	10-UNV-BV-MATFLG
12" Mating Flange	12-UNV-BV-MATFLG
10" Mating Flange w/ Collar	10-UNV-BV-MATFLGC
12" Mating Flange w/ Collar	12-UNV-BV-MATFLGC

Ladders

P/N

Carbon Steel Ladder (per foot)	20-CS-LAD
Fall Arrest System (20'-0"/30'-0"/40'-0"/50'-0"/60'-0")	20-FALL-ASM

Load Cells

P/N

2,500# Load Cell	CAR-2500LC
5,000# Load Cell	CAR-5000LC
15,000# Load Cell	CAR-15000LC

Manhole

P/N

20" Manhole Assembly	20-MH-ASM
18" Manhole Foam Gasket (Old Style)	18-MH-GAS
20" Manhole Foam Gasket (Old Style)	20-MH-GAS
20" Manhole Urethane Gasket (New Style)	20-MH-GAS-N
20" Low Level Manhole	20-MHLL-ASM

Manifold

P/N

8-Port Manifold	8PORT-STD-MFLD
8-Port Manifold (Low Pressure)	8PORT-LOPRESS-MFLD

Motors

P/N

5 HP 3Ph Electric Motor	TOS-5TC-3PH
10 HP 3Ph Electric Motor	TOS-10T-3PH / TOS-10TC-3PH
20 HP 3Ph Electric Motor	TOS-20T-3PH / TOS-20TC-3PH
25 HP 3Ph Electric Motor	TOS-25T-3PH / TOS-25TC-3PH
30 HP 3Ph Electric Motor	TOS-30T-3PH
40 HP 3Ph Electric Motor	TOS-40T-3PH
5 HP 1 Ph Electric Motor	WEG-5TC-1PH)
10 HP 1 Ph Electric Motor	WEG-10TC-1PH)
18 HP Gas Motor (with clutch)	BS-18HPGAS

Parts and Accessories

Pinch Valves	P/N
4" Anti-Overfill Pinch Valve	4-PV-ASM
5" Anti-Overfill Pinch Valve	5-PV-ASM
4" Pinch Valve Only with Flanges and Hardware	4-PV
5" Pinch Valve Only with Flanges and Hardware	5-PV
Pinch Valve Control Box	PV-ASM-CB
Mac 113B Pinch Valve Solenoid	MAC113B-PV-SOL
Pressure Relief Valve	P/N
8" Pressure Relief Valve Assembly	8PR-VALVE-ASM
8" Pressure Relief Valve Gasket	8PR-VALVE-GAS
8" Pressure Relief Valve Spring, Bolt, & Nut	8-PRV-SPRBN
Portable Discharge Spouts	P/N
10" x 4' -0" Discharge Spout	10SPT-4-0
12" x 4' -0" Discharge Spout	12SPT-4-0
Portable Extension Tubes	P/N
8" x 3' -5" Extension Tube	8EXT-3-5
10" x 3' -2" Extension Tube	10EXT-3-2
12 3/4" X 3' -0" Extension Tube	12EXT-3-0
Shafts	P/N
1 1/4" x 7" Tail Shaft	125SHFT-7T
1 1/4" x 8 1/2" Drive Shaft	125SHFT-85D
1 1/4" x 11 1/2" Drive Shaft	125SHFT-115D
1 1/4" x 15 1/2" Drive Shaft	125SHFT-155D
1 1/2" x 8 1/2" Tail Shaft	15SHFT-85T
1 1/2" x 11 1/2" Drive Shaft	15SHFT-115D
1 1/2" x 15 1/2" Drive Shaft	15SHFT-155D
1 15/16" x 9" Tail Shaft	19SHFT-9T
1 15/16" x 10 1/2" Drive Shaft	19SHFT-105D
1 15/16" x 15 1/2" Drive Shaft	19SHFT-155D
2" x 9" Tail Shaft	2SHFT-9T
2" x 10 1/2" Drive Shaft	2SHFT-105D
2" x 15 1/2" Drive Shaft	2SHFT-155D

Parts and Accessories

Vibrators P/N

VS- 190 (Air) Vibrator	VS-190-AIRVIB
VS- 380 (Air) Vibrator	VS-380-AIRVIB
2P- 75 (Electric) Vibrator	2P-75-ELECVIB
2P- 150 (Electric) Vibrator	20-150-ELECVIB
50- 1 1/2 Piston Style Vibrator with Bracket	50-15-PIVIB

Vinyl Boot Sock w/ Clamp P/N

10 3/4" x 4'-0" Long Vinyl Boot Sock w/ Clamp	1075VBS-4-0
10 3/4" x 6'-0" Long Vinyl Boot Sock w/ Clamp	1075VBS-6-0
12 3/4" x 3'-0" Long Vinyl Boot Sock w/ Clamp	1275VBS-3-0

Vinyl Boot Sock Clamps P/N

10 3/4" Clamp	HC-10
12 3/4" Clamp	HC-12

Wam Accessories P/N

10" Butterfly Valve	V1FS10G
12" Butterfly Valve	V1FS12G
Air Actuator	CP101-ACT
Actuator Repair Kit	CP101-RPKIT
Replacement Gasket	XSL-10
Manual Handle	CM2
Limit Switch	MIC23
Single Solenoid with Coil	V5V81
Double Solenoid with Coils	V5V82
10" Mating Flange	10UNV-BV-MATFLG
12" Mating Flange	12UNV-BV-MATFLG
10" Mating Flange w/ Collar	10-UNV-BV-MATFLGC
12" Mating Flange w/ Collar	12-UNV-BV-MATFLGC
ACME Replacement Brass Brushing VLQ Gate	VLQ-RPL-BSH

Misc. P/N

Mac 93A-AAB Single Solenoid with Coil	93A-AAB
Mac 93A-AAB Single Solenoid with Coil and Manifold Base	93A-AAB-SUB
Mac 93A-EAB Double Solenoid with Coils	93A-EAB
Mac 93A-EAB Double Solenoid with Coils and Manifold Base	93A-EAB-SUB
Pulse Jet Dust House Solenoid with Coil	330-PJDH-SOLC
Pulse Jet Dust House Timer Board	330-PJDH-TB
MC202-D03TF Camozzi Filter / Regulator w/ Guage & Fittings	MC202-FRG
MC238-ROOTF Camozzi Regulator, Guage & Fittings	MC238-AIRPD-REG
Camozzi Manual Air Control Valve Single	454-900TF
Camozzi Manual Air Control Valve Double	464-905TF



Belgrade Steel Tank Co., Inc.

P.O. Box 220
405 Lowery Avenue
Belgrade, MN 56312

Phone: (320) 254-8246
Fax: (320) 254-3458
www.belgradesteeltank.com

